

6

5

4

3

2

1

D

D

C

C

B

B

A

A

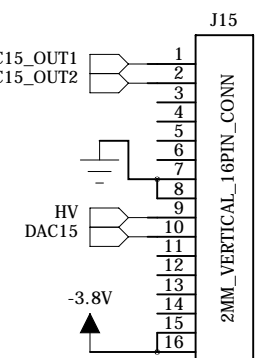
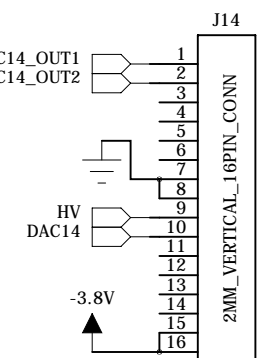
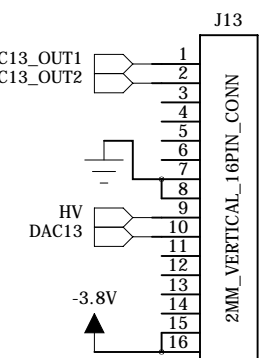
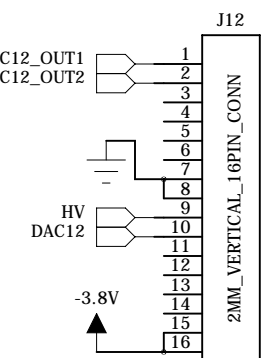
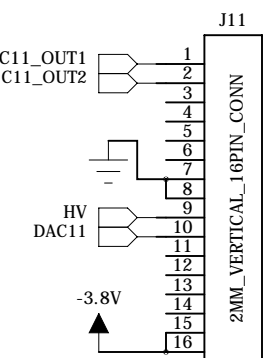
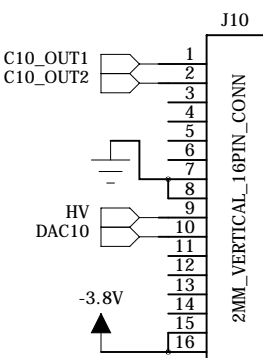
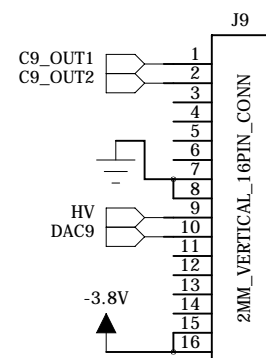
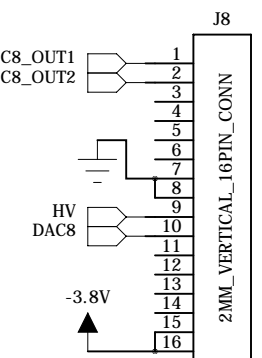
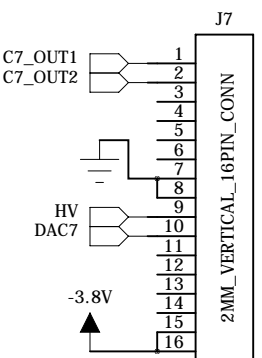
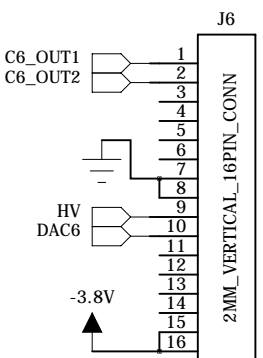
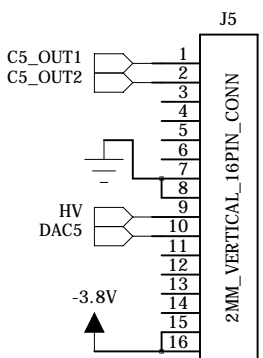
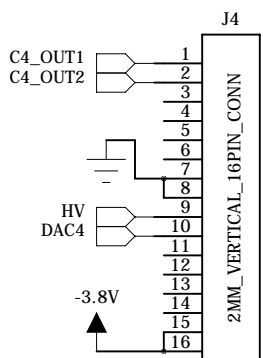
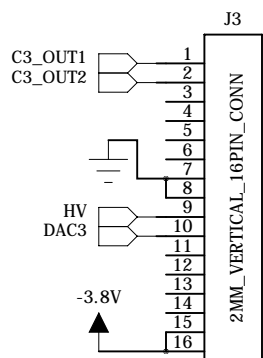
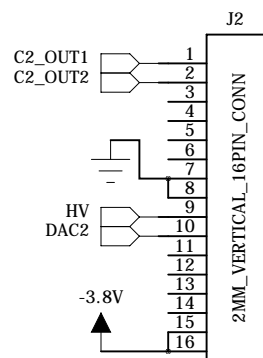
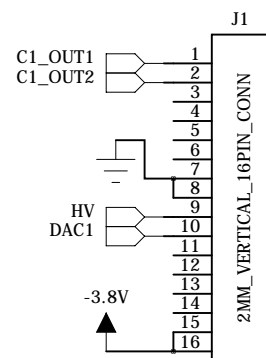
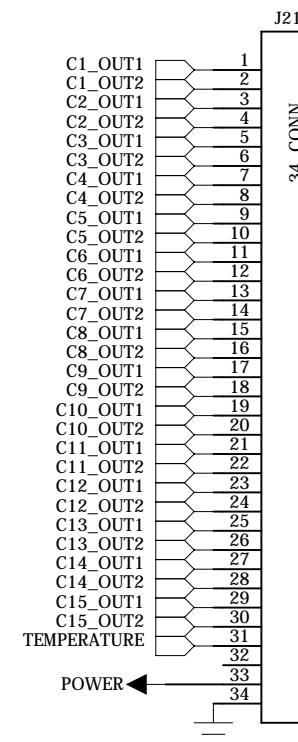
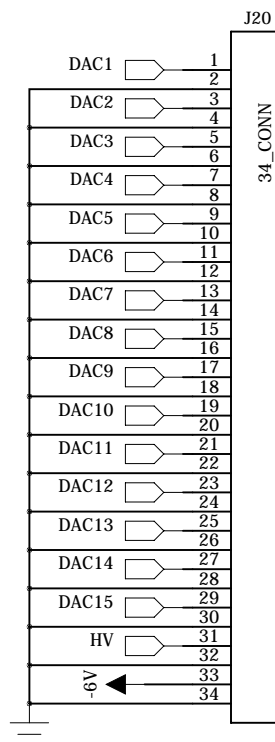
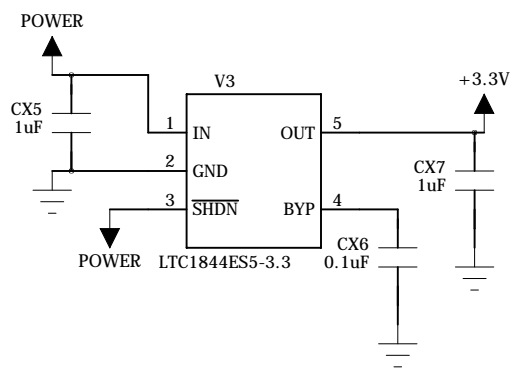
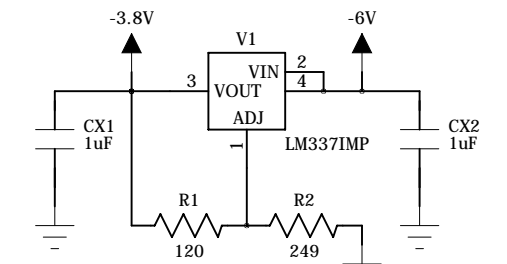
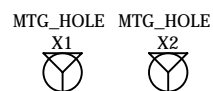
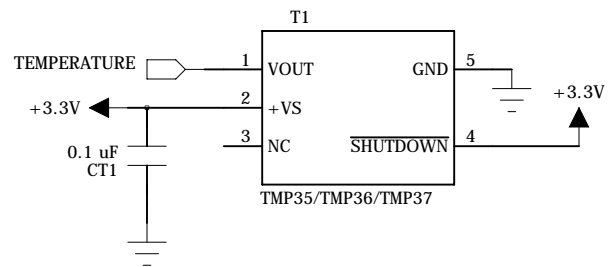

Univ. of Hawai'i -- Instr. Dev. Lab.

TITLE: KLM_Preamplifier_Carrier_Card



Design:

Page Description:

REV:

Top

A

DATED: 03-August-2010

SHEET: 1 of 1