

6

5

4

3

2

1

E

E

D

D

C

C

B

B

A

A

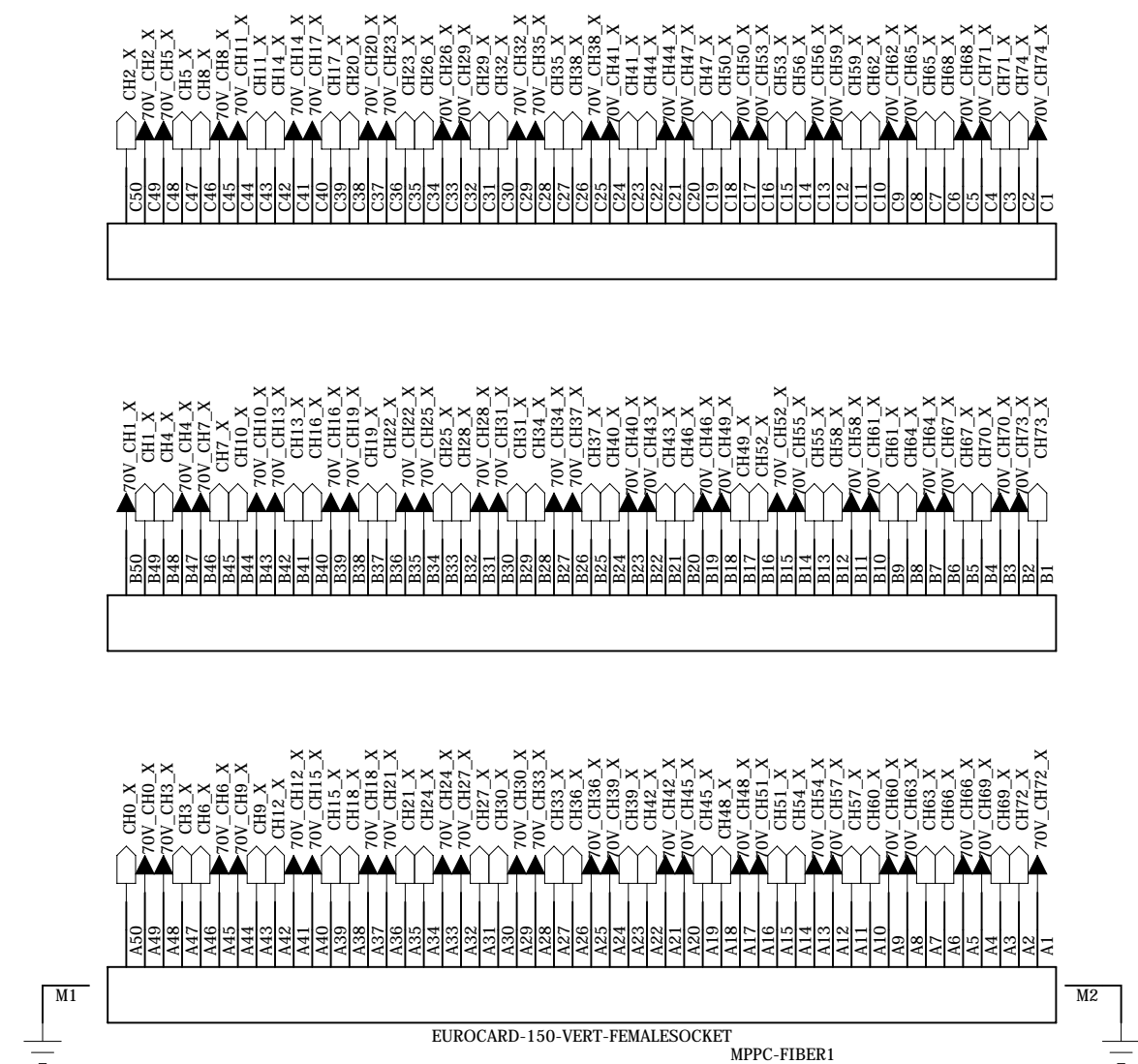

institution:	University of Hawaii at Manoa High Energy Physics Lab Instrumentation Development Lab
title:	MB_SciFi_Tracker
revision:	C
IDLAB design #:	IDL_14_017
circuit design:	GSV XS
PCB design:	XS
sheet #:	
sheet description:	
date last modified:	May-27-2014

6

5

4

3

2

1

E

E

D

D

C

C

B

B

A

A

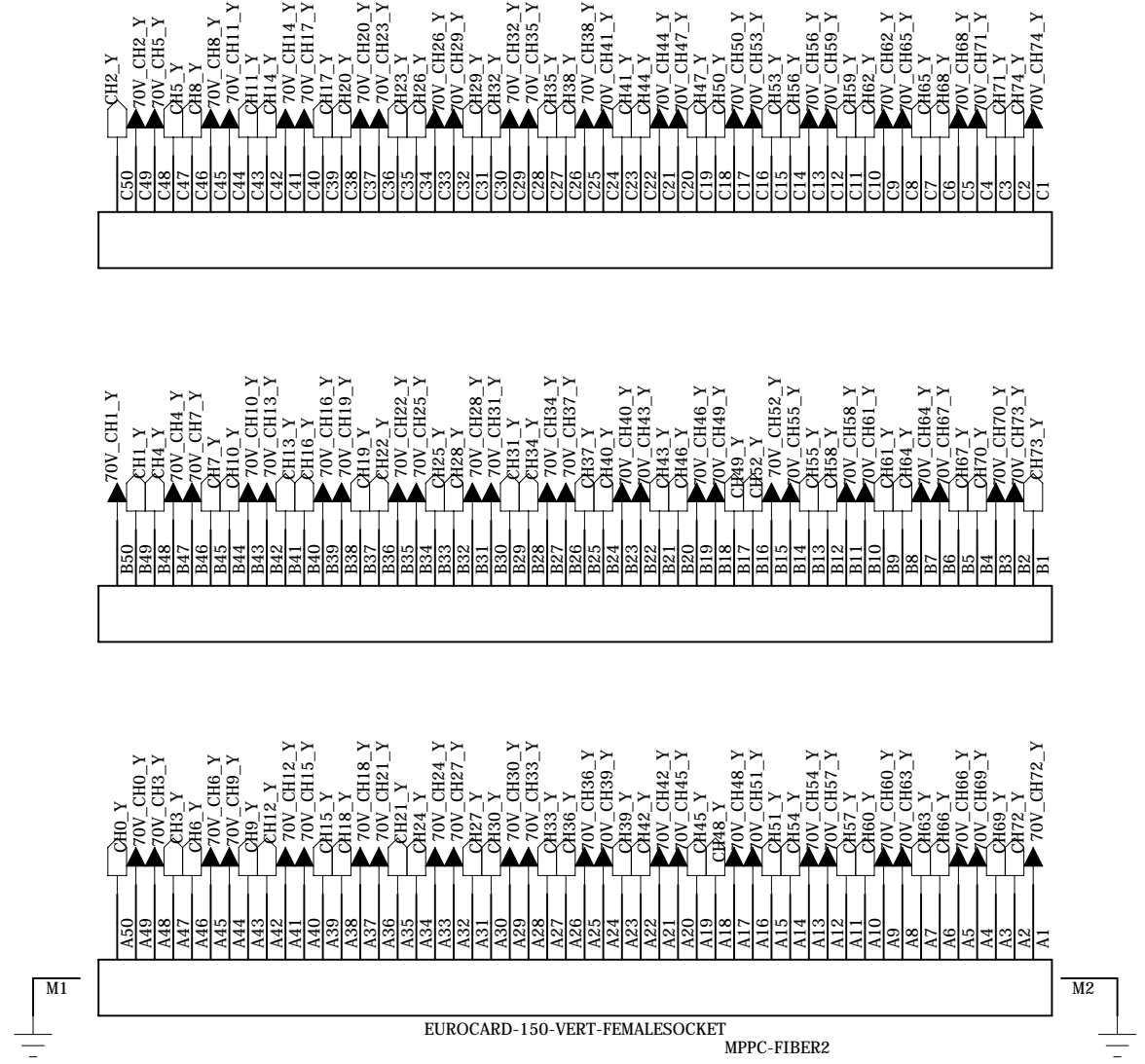

institution:	University of Hawaii at Manoa High Energy Physics Lab Instrumentation Development Lab
title:	MB_SciFi_Tracker
revision:	C
IDLAB design #:	IDL 14 017
circuit design:	GSV XS
PCB design:	XS
sheet #:	
sheet description:	
date last modified:	May-27-2014

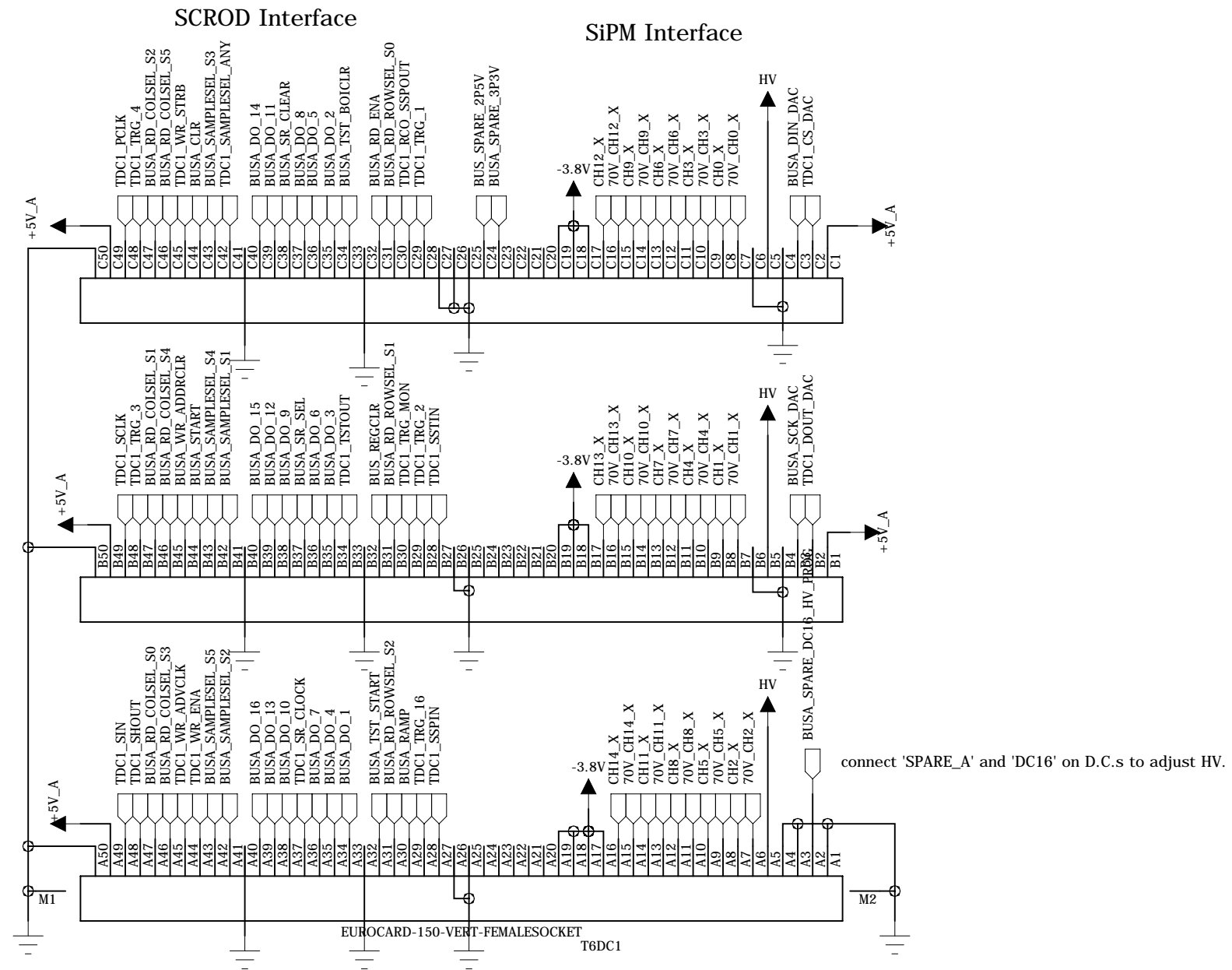

institution:	University of Hawaii at Manoa High Energy Physics Lab Instrumentation Development Lab
title:	MB_SciFi_Tracker
revision:	C
IDLAB design #:	IDL_14_017
circuit design:	GSV XS
PCB design:	XS
sheet #:	
sheet description:	
date last modified:	May-27-2014

6

5

4

3

2

1

E

E

D

D

C

C

B

B

A

A

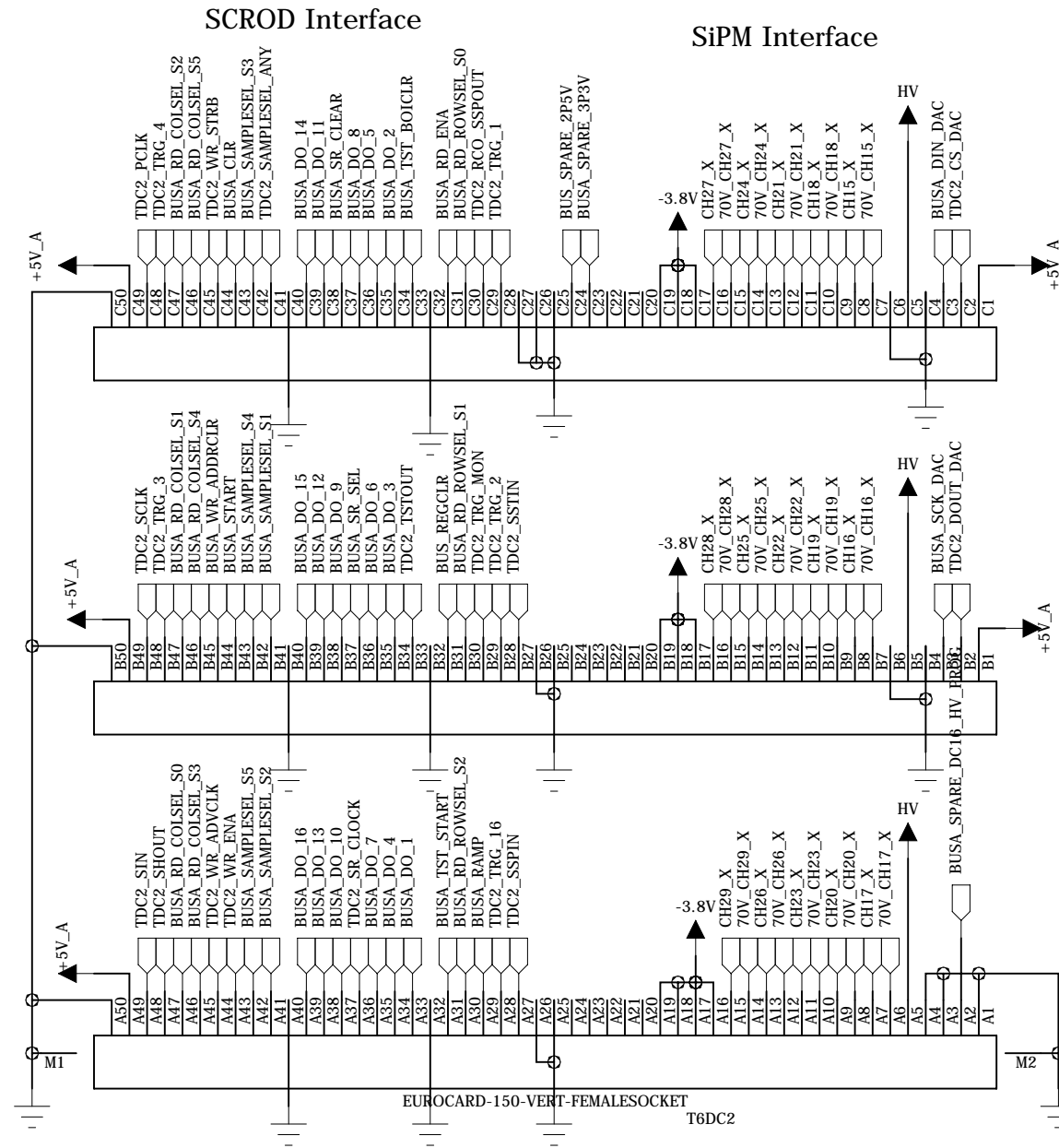

institution:	University of Hawaii at Manoa High Energy Physics Lab Instrumentation Development Lab
title:	MB_SciFi_Tracker
revision:	C
IDLAB design #:	IDL_14_017
circuit design:	GSV_XS
PCB design:	XS
sheet #:	
sheet description:	
date last modified:	May-27-2014

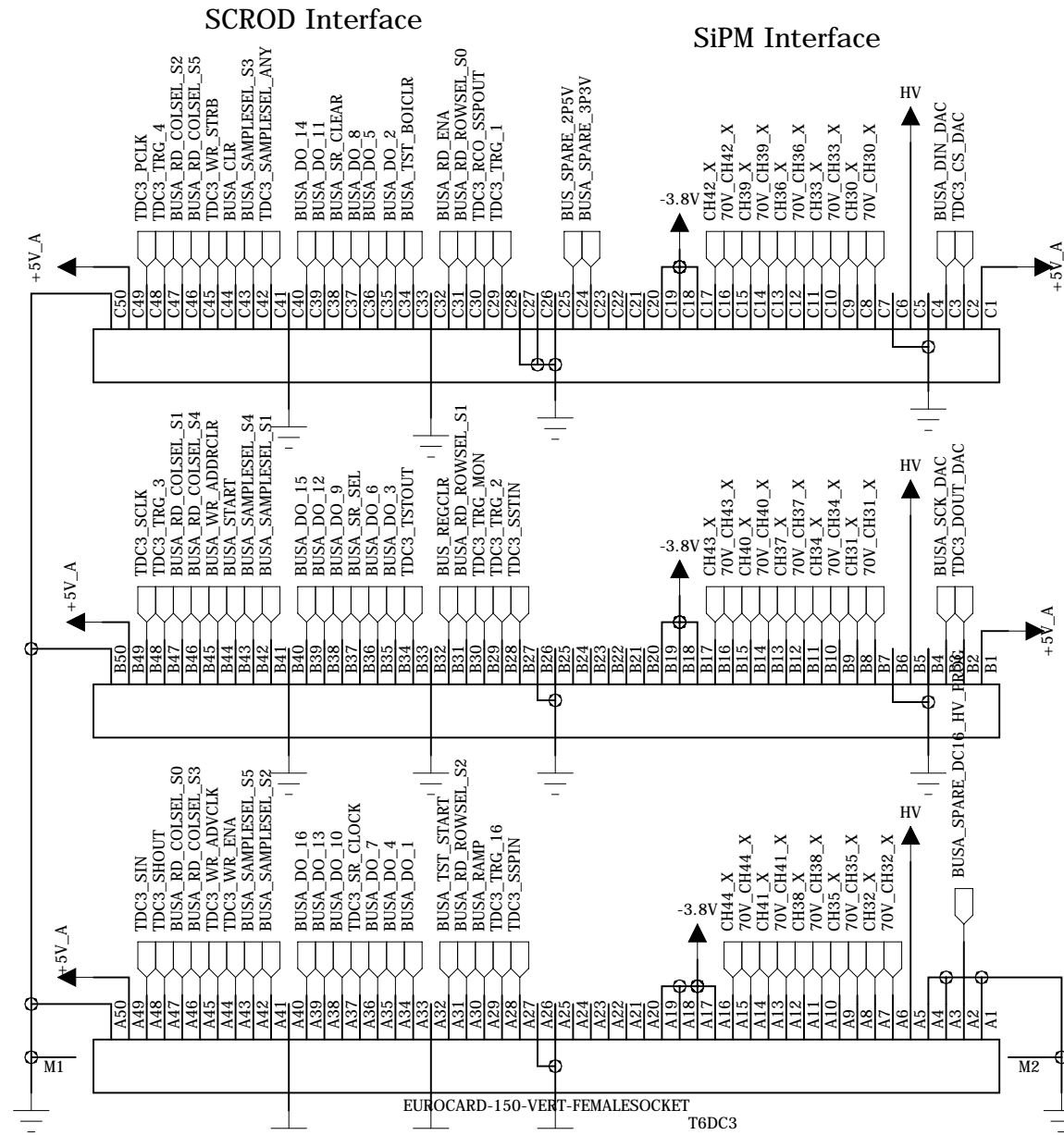

institution:	University of Hawaii at Manoa High Energy Physics Lab Instrumentation Development Lab
title:	MB_SciFi_Tracker
revision:	C
IDLAB design #:	IDL_14_017
circuit design:	GSV_XS
PCB design:	XS
sheet #:	
sheet description:	
date last modified:	May-27-2014

E

E

D

D

C

C

B

B

A

A

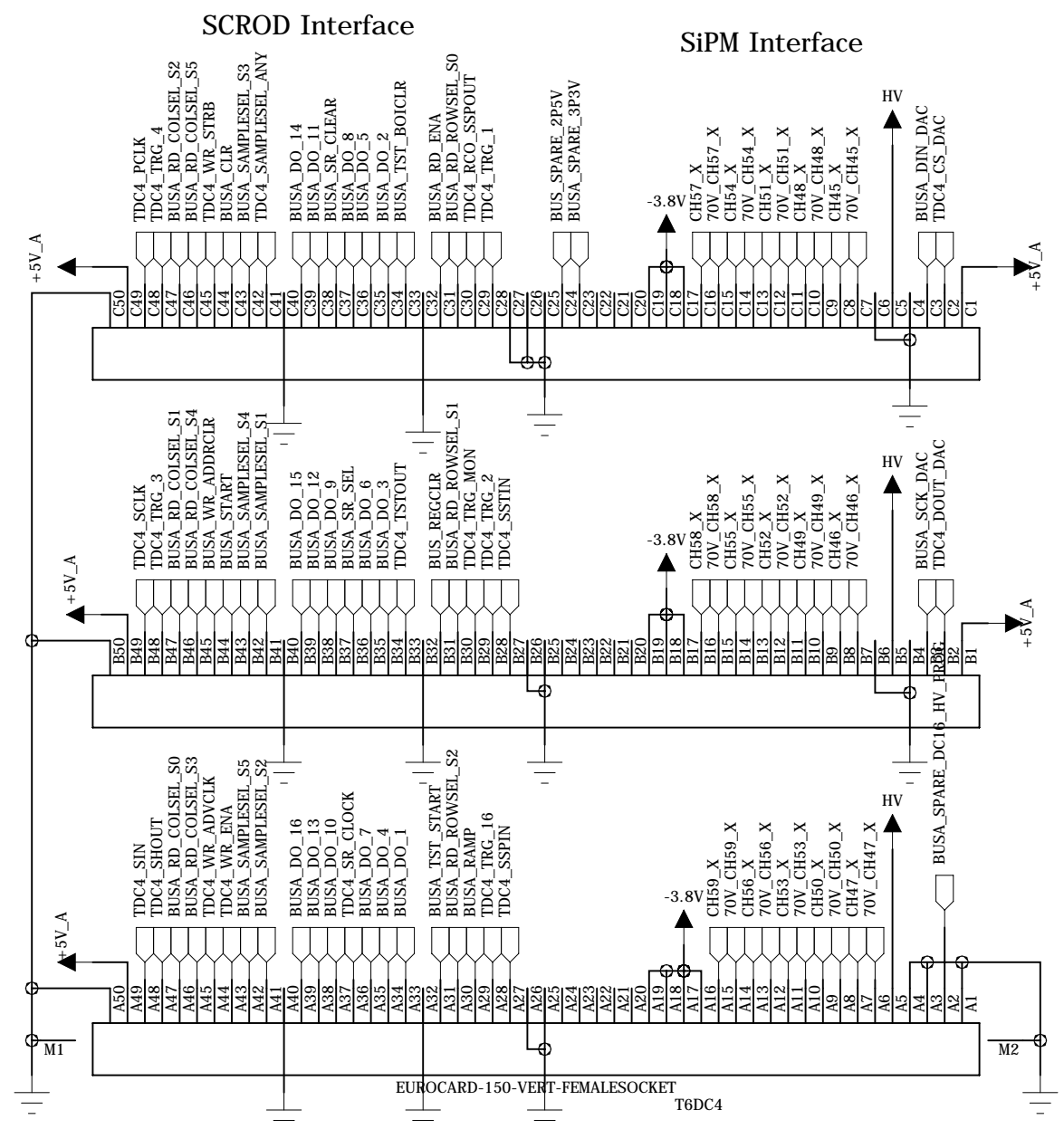

institution:	University of Hawaii at Manoa High Energy Physics Lab Instrumentation Development Lab
title:	MB_SciFi_Tracker
revision:	C
IDLAB design #:	IDL_14_017
circuit design:	GSV XS
PCB design:	XS
sheet #:	
sheet description:	
date last modified:	May-27-2014

E

E

D

D

C

C

B

B

A

A

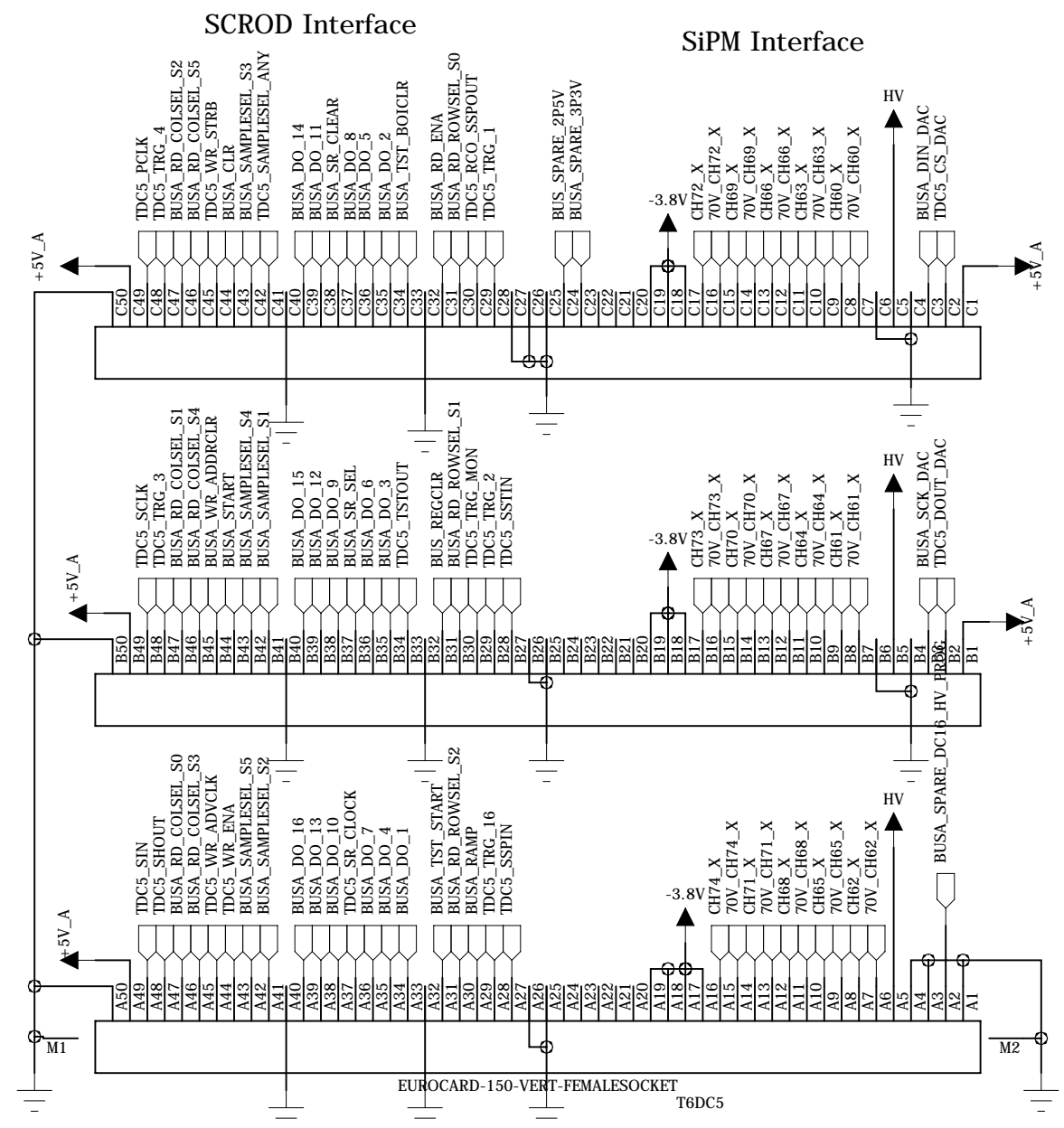

institution:	University of Hawaii at Manoa High Energy Physics Lab Instrumentation Development Lab
title:	MB_SciFi_Tracker
revision:	C
IDLAB design #:	IDL_14_017
circuit design:	GSV_XS
PCB design:	XS
sheet #:	
sheet description:	
date last modified:	May-27-2014

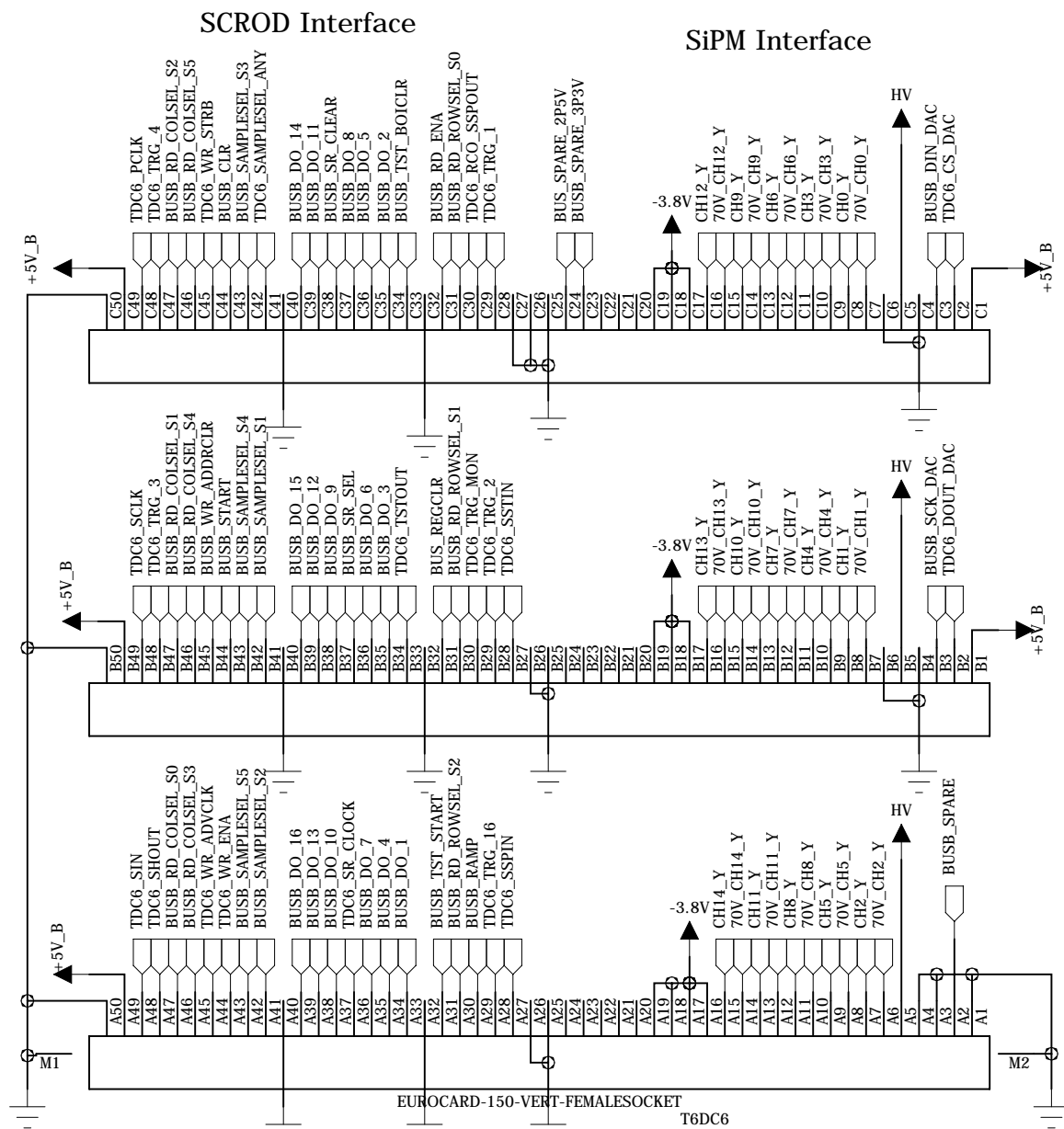

institution:	University of Hawaii at Manoa High Energy Physics Lab Instrumentation Development Lab
title:	MB_SciFi_Tracker
revision:	C
IDLAB design #:	IDL 14 017
circuit design:	GSV XS
PCB design:	XS
sheet #:	
sheet description:	
date last modified:	May-27-2014

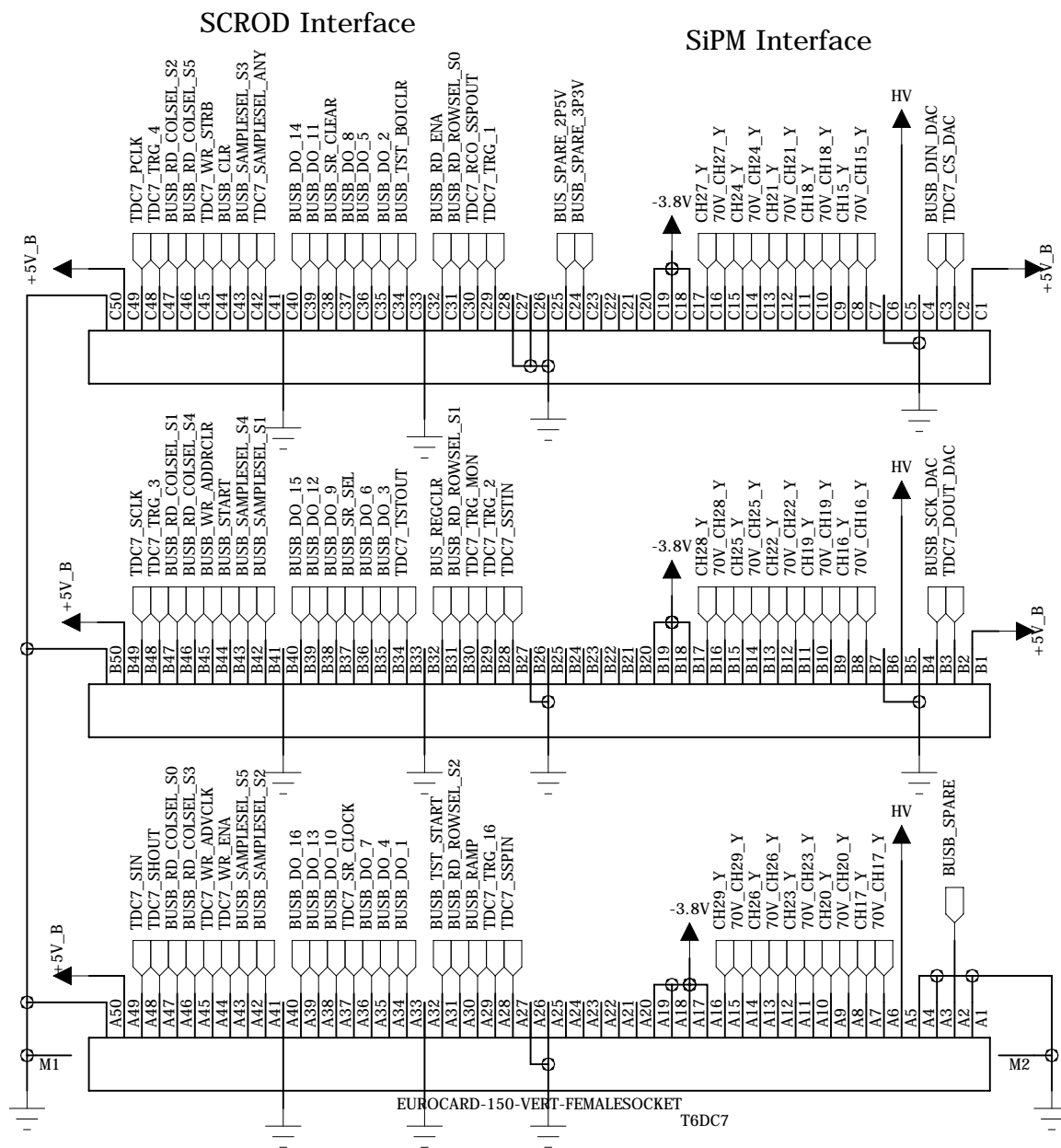

institution:	University of Hawaii at Manoa High Energy Physics Lab Instrumentation Development Lab
title:	MB_SciFi_Tracker
revision:	C
IDLAB design #:	IDL_14_017
circuit design:	GSV_XS
PCB design:	XS
sheet #:	
sheet description:	
date last modified:	May-27-2014

E

E

D

D

C

C

B

B

A

A

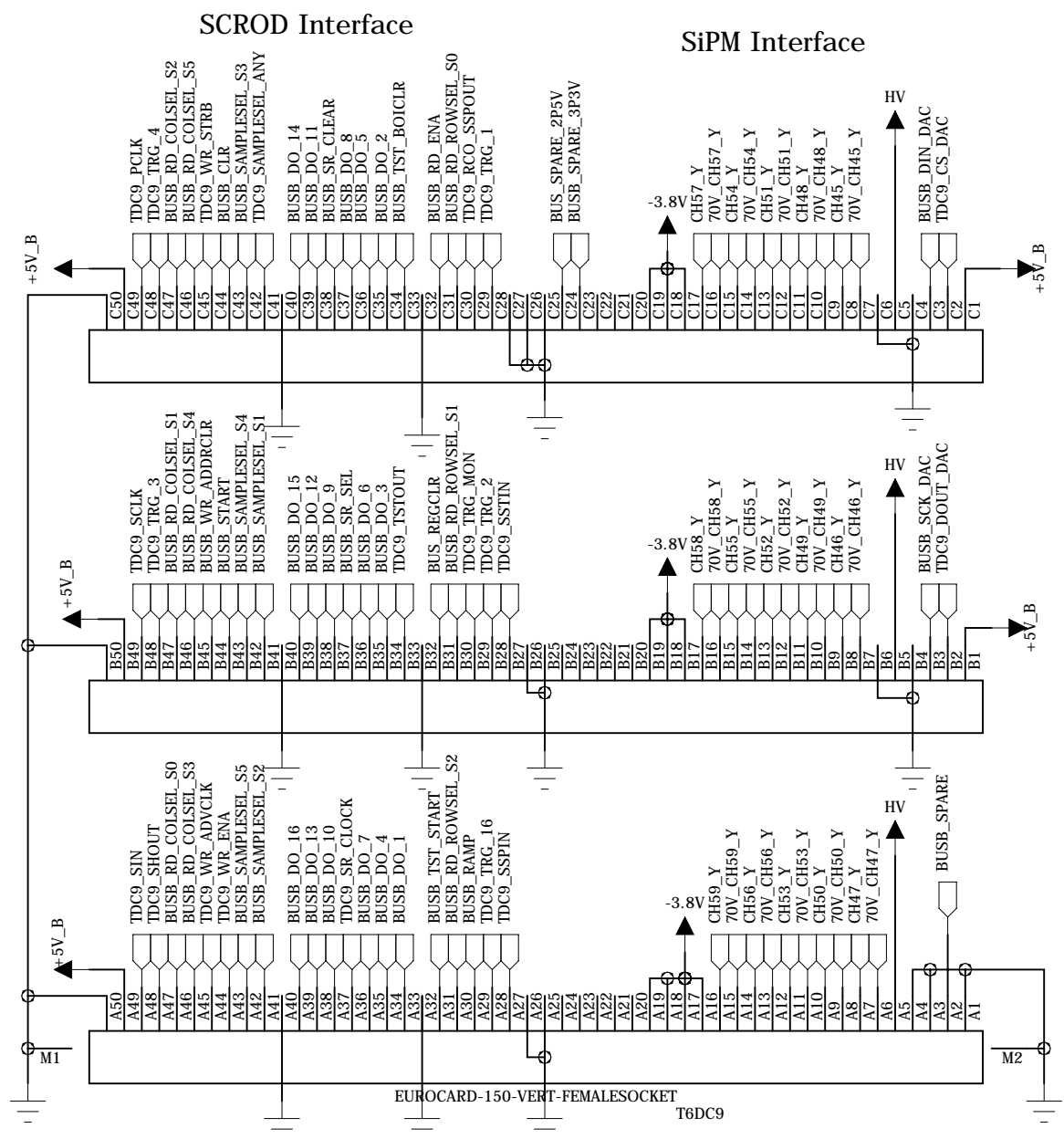

institution:	University of Hawaii at Manoa High Energy Physics Lab Instrumentation Development Lab
title:	MB_SciFi_Tracker
revision:	C
IDLAB design #:	IDL_14_017
circuit design:	GSV_XS
PCB design:	XS
sheet #:	
sheet description:	
date last modified:	May-27-2014

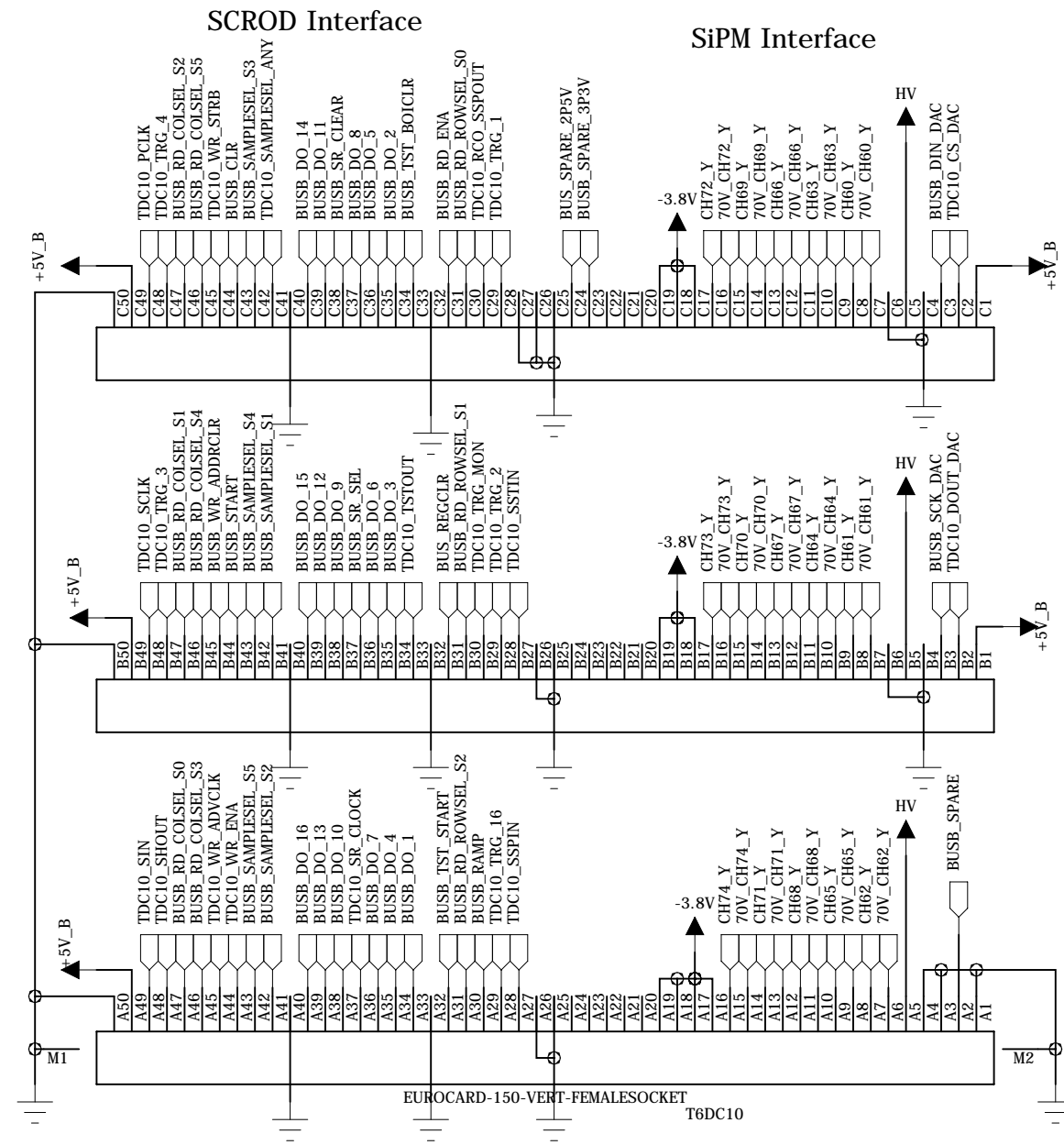

institution:	University of Hawaii at Manoa High Energy Physics Lab Instrumentation Development Lab
title:	MB_SciFi_Tracker
revision:	C
IDLAB design #:	IDL_14_017
circuit design:	GSV XS
PCB design:	XS
sheet #:	
sheet description:	
date last modified:	May-27-2014

6

5

4

3

2

1

E

E

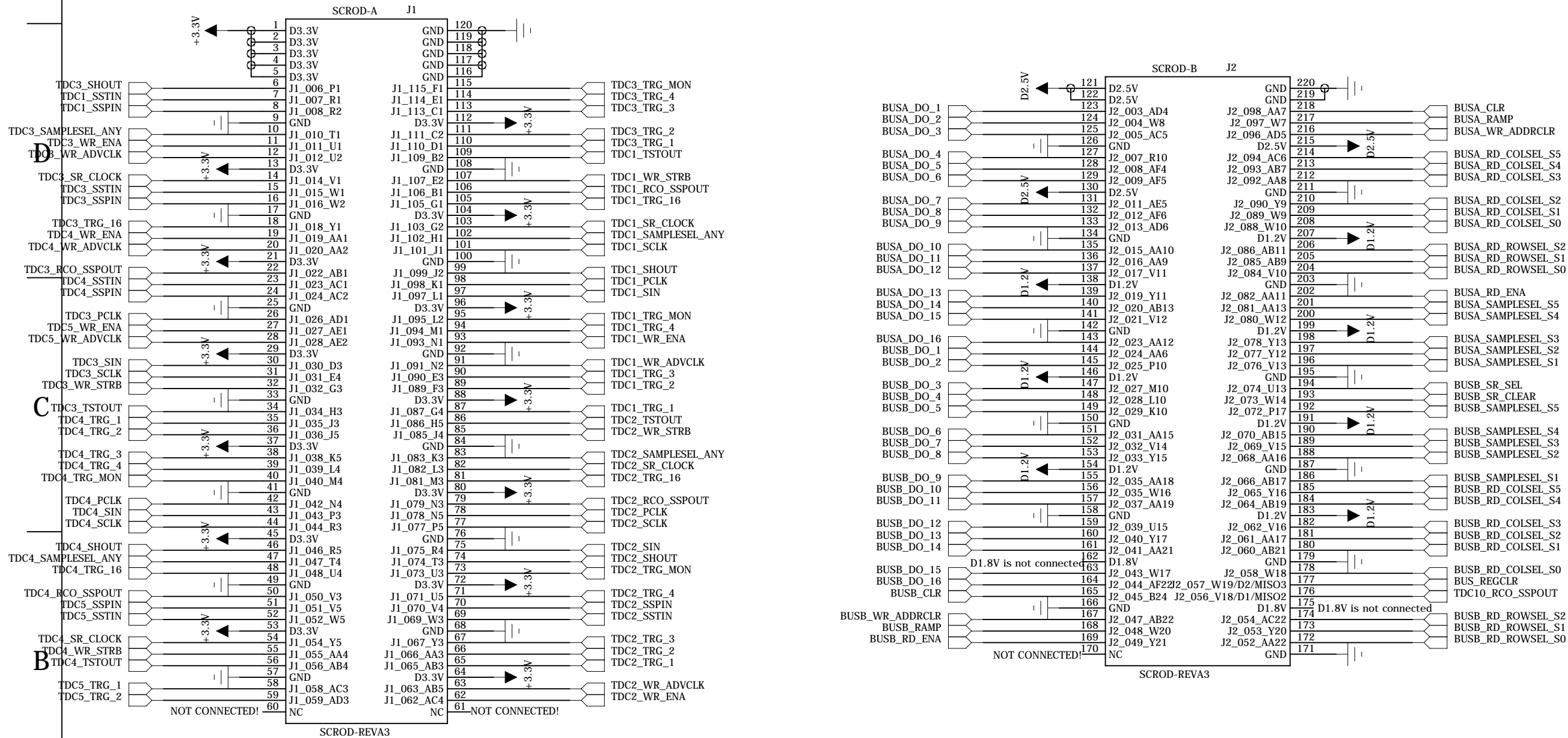

D

C

B

A

A

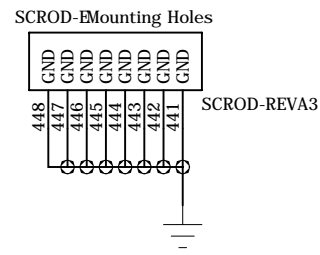

institution:	University of Hawaii at Manoa High Energy Physics Lab Instrumentation Development Lab
title:	MB_SciFi_Tracker
revision:	C
IDLAB design #:	IDL 14 017
circuit design:	GSV XS
PCB design:	XS
sheet #:	
sheet description:	
date last modified:	May-27-2014

6

5

4

3

2

1

E

E

D

D

C

C

B

B

A

A

LEMO2
LEMO_EPL.00.113.NLN

RIGGER1

EX_TRIGGER2
LEMO2

LEMO1
LEMO_EPL.00.113.NLN

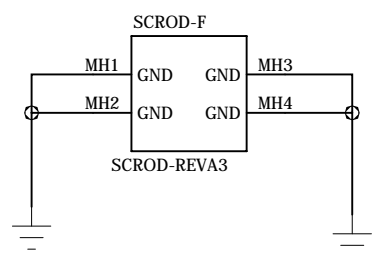
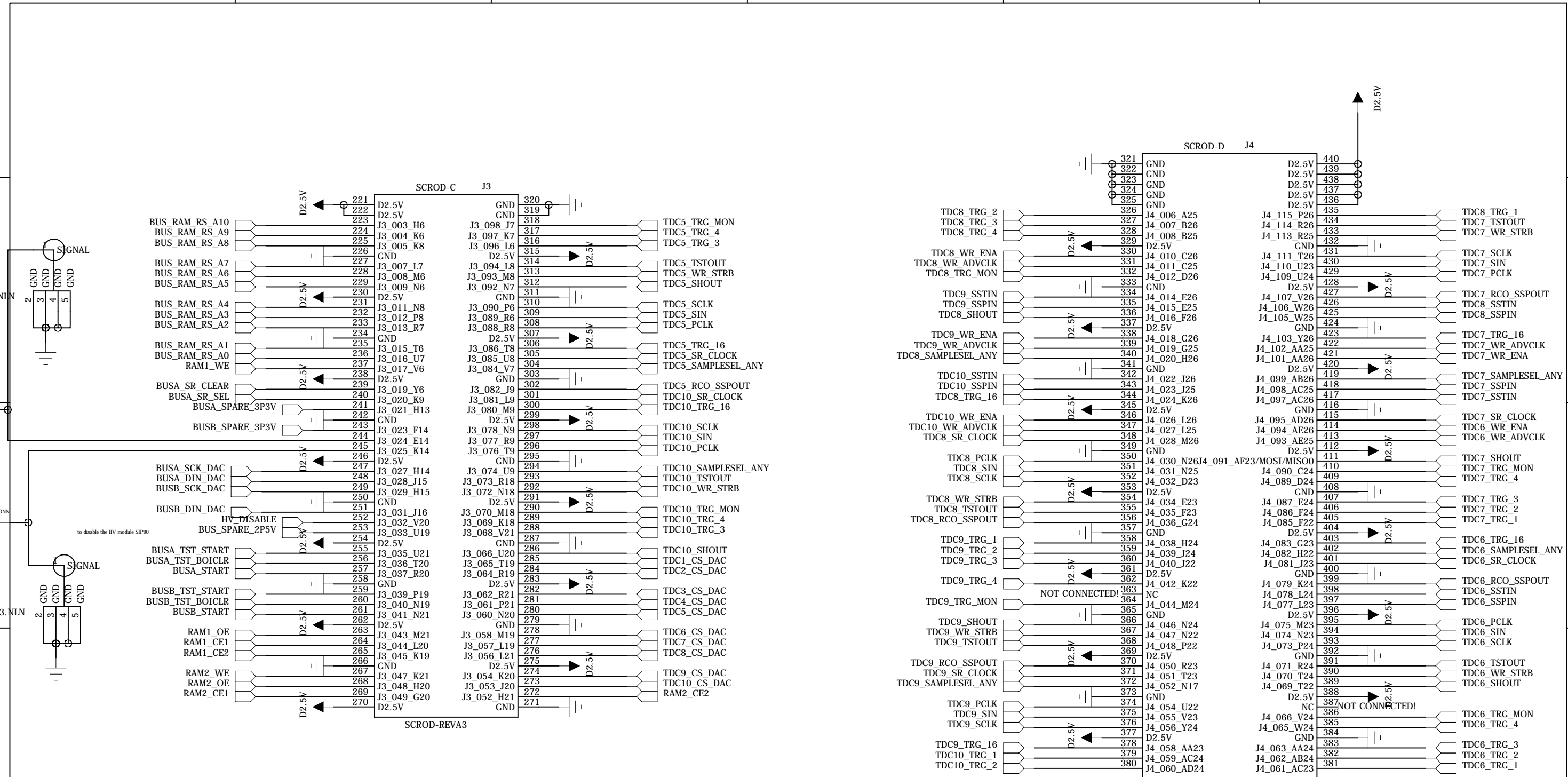

institution:	University of Hawaii at Manoa High Energy Physics Lab Instrumentation Development Lab
title:	MB_SciFi_Tracker
revision:	C
IDLAB design #:	IDL_14_017
circuit design:	GSV XS
PCB design:	XS
sheet #:	
sheet description:	
date last modified:	May-27-2014

6

5

4

3

2

'SPARE_A' pins on D.C. 6, 7, 8, 9, 10

E

E

D

D

C

C

B

B

A

A

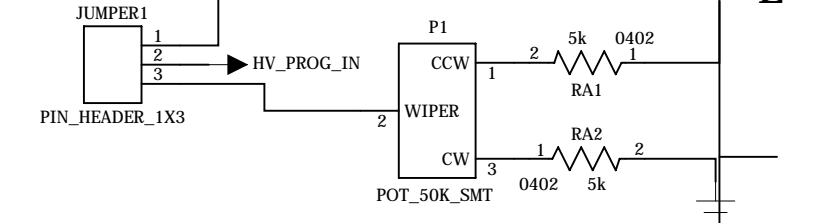
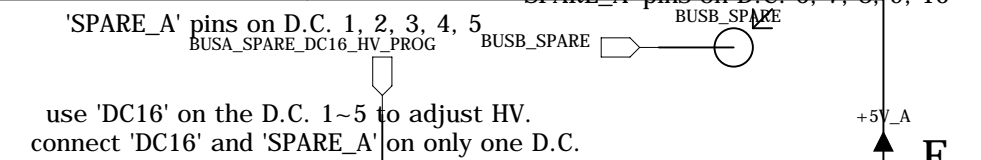
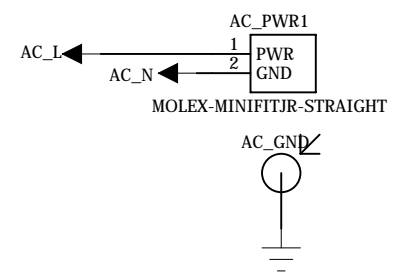
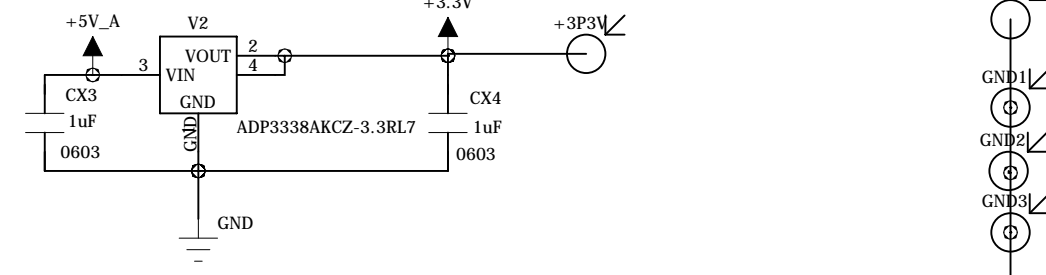

Vprog	Vout
0.5	83.45
1.4	70.76
3.3	43.97

Vout=90.5-14.1*Vprog

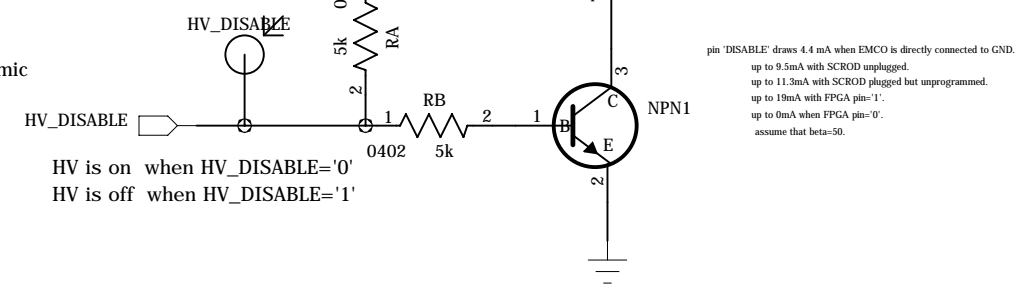
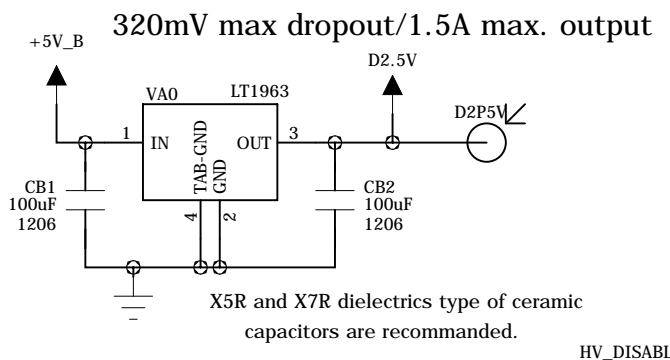
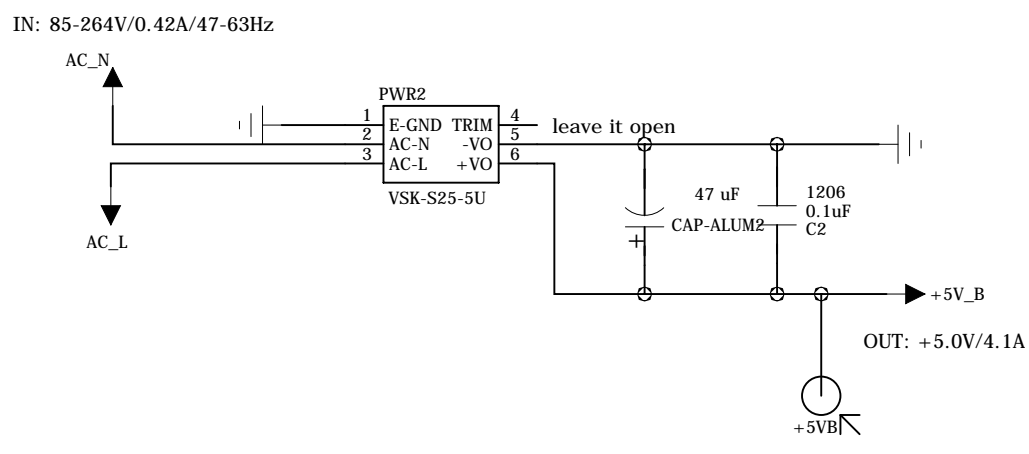
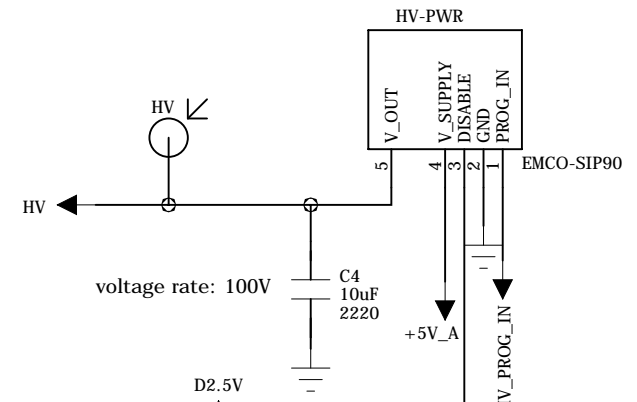
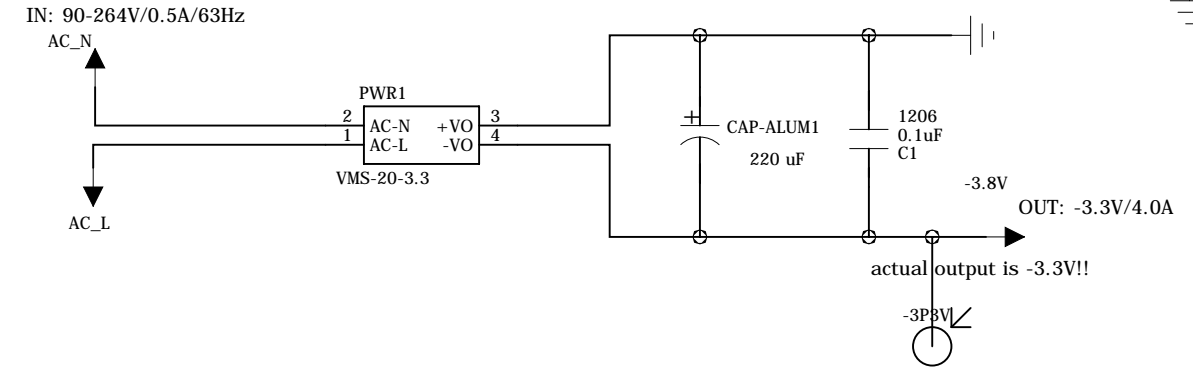

pin 'DISABLE' draws 4.4 mA when EMCO is directly connected to GND.
 up to 9.5mA with SCROD unplugged.
 up to 11.3mA with SCROD plugged but unprogrammed.
 up to 19mA with FPGA pins='1'.
 up to 0mA when FPGA pins='0'.
 assume that beta=50.

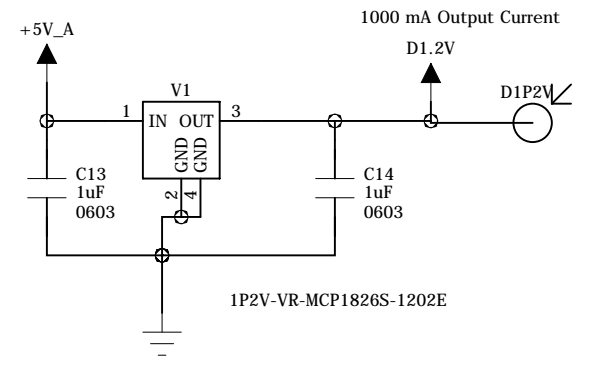
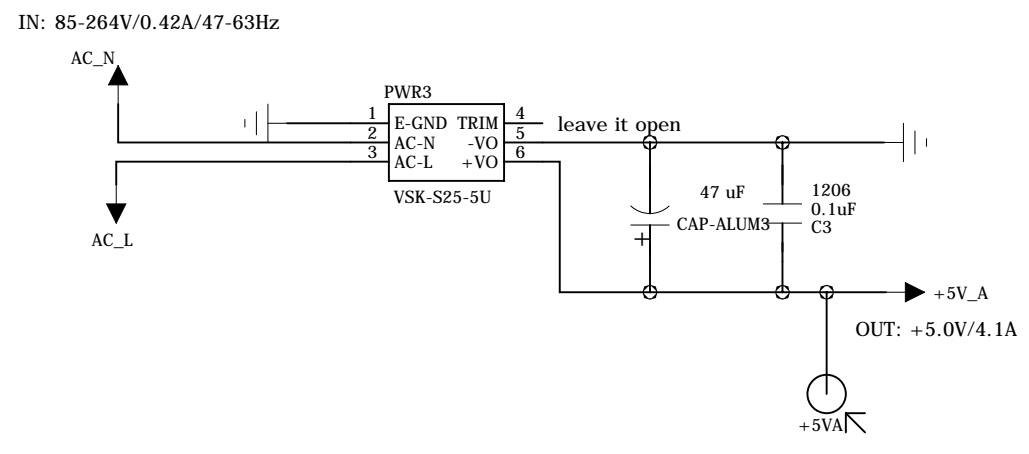

institution:	University of Hawaii at Manoa High Energy Physics Lab Instrumentation Development Lab
title:	MB_SciFi_Tracker
revision:	C
IDLAB design #:	IDL_14_017
circuit design:	GSV XS
PCB design:	XS
sheet #:	
sheet description:	
date last modified:	May-27-2014

6

5

4

3

2

1

E

E

D

D

C

C

B

B

A

A

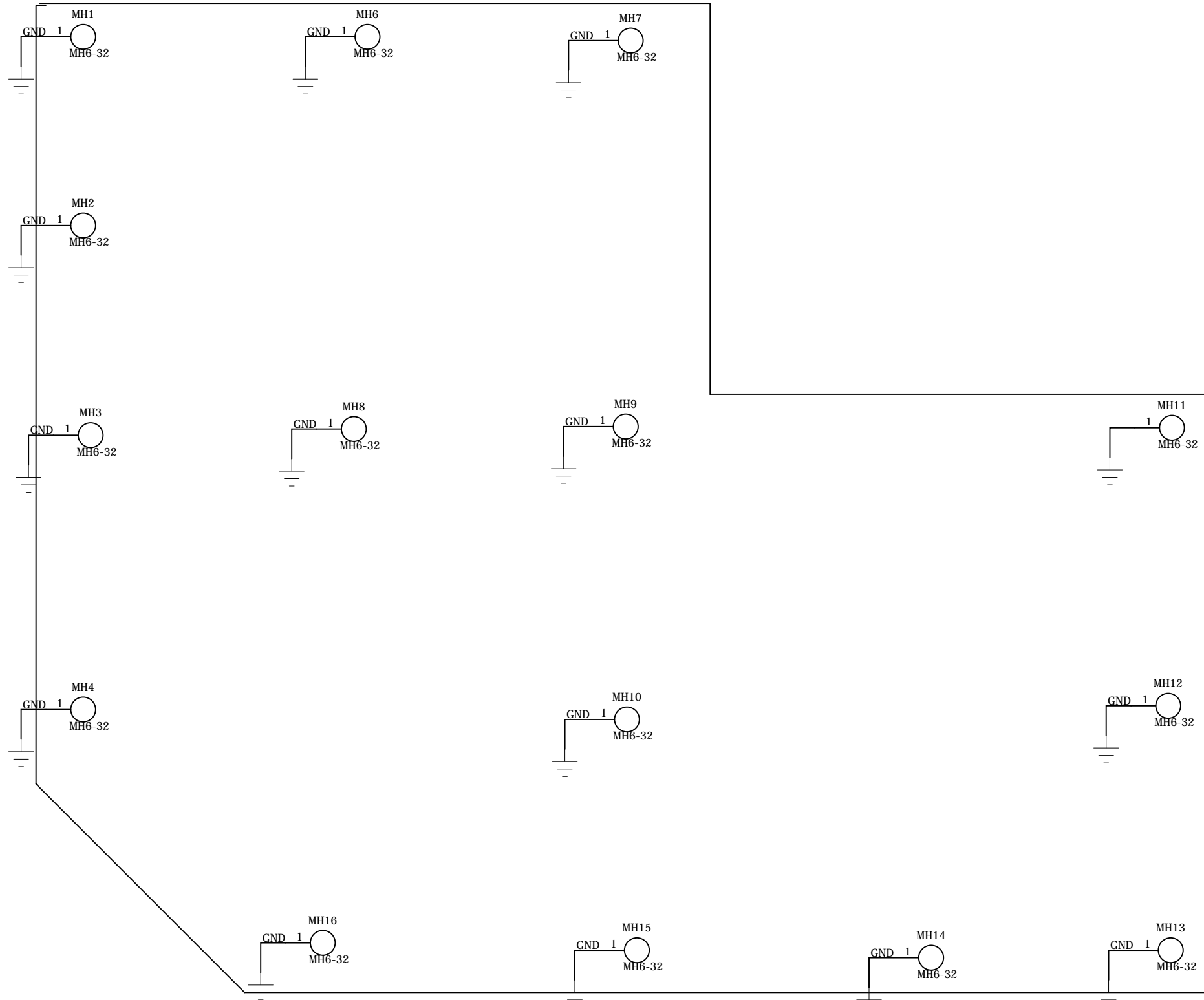

institution:	University of Hawaii at Manoa High Energy Physics Lab Instrumentation Development Lab
title:	MB_SciFi_Tracker
revision:	C
IDLAB design #:	IDL 14 017
circuit design:	GSV XS
PCB design:	XS
sheet #:	
sheet description:	
date last modified:	May-27-2014

E

E

D

D

C

C

B

B

A

A

Typical active current: 4.5 mA at f = 1 MHz

RAM1 and RAM2 share the address bus.

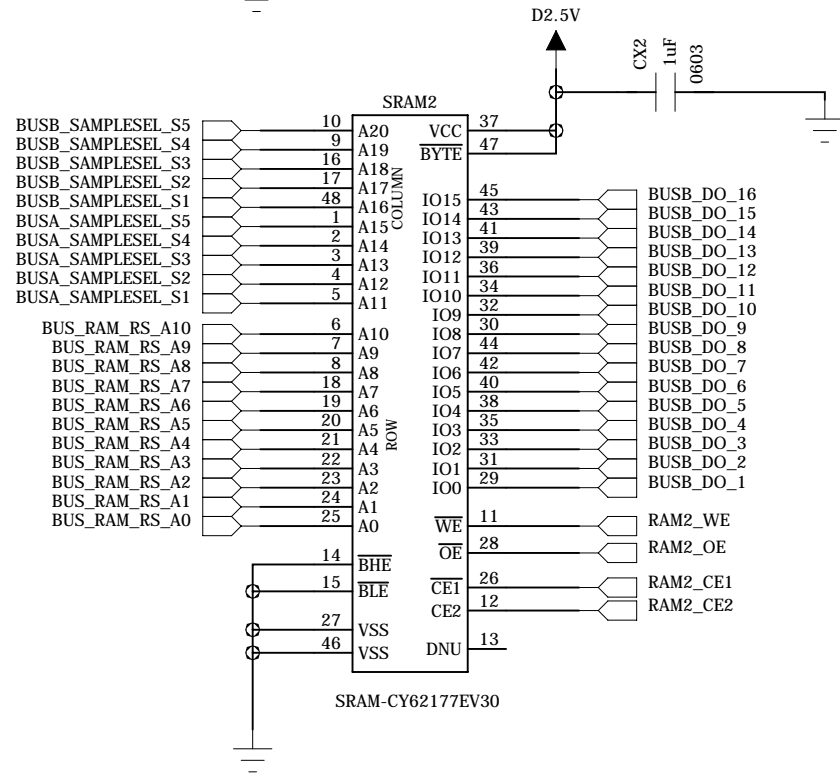
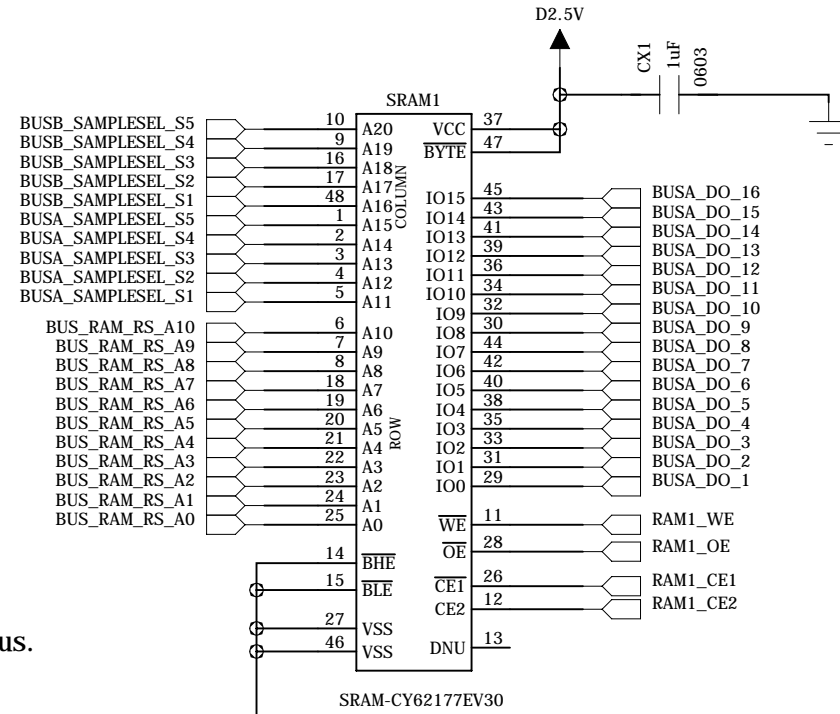

institution:	University of Hawaii at Manoa High Energy Physics Lab Instrumentation Development Lab
title:	MB_SciFi_Tracker
revision:	C
IDLAB design #:	IDL_14_017
circuit design:	GSV XS
PCB design:	XS
sheet #:	
sheet description:	
date last modified:	May-27-2014