

High Energy Physics Group, Instrumentation Development Lab		Designer: Jose Duron	ID/LAB design #:
Board:	WATCHMAN TC Prototype	Drawn By:	C
Sheet Title:	TARGETX	Approved By: Gary Varner	Revision: [No Variations]
		A A	Modif Date: 8/13/2018
			Sheet 1 of 7

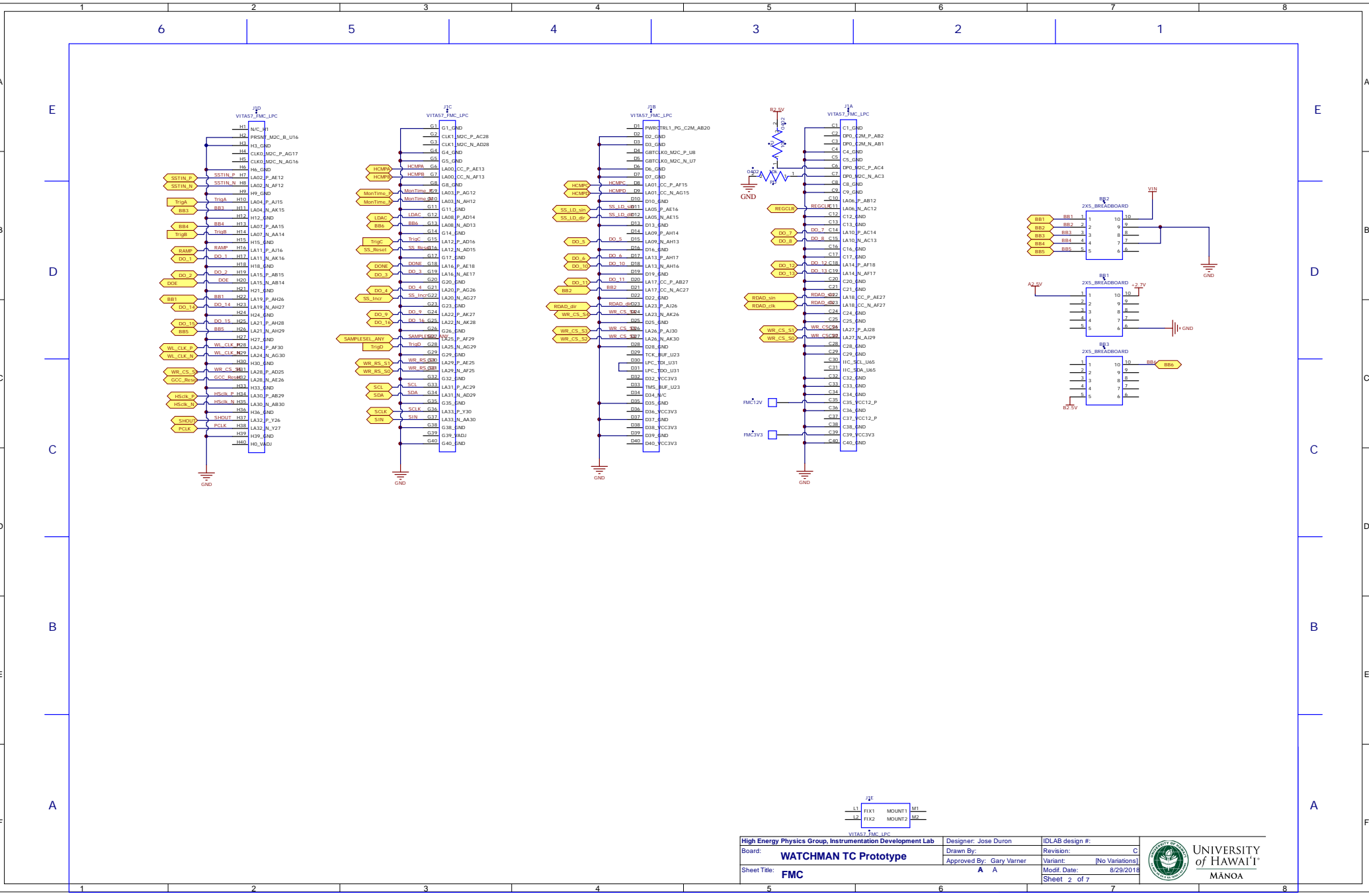



High Energy Physics Group, Instrumentation Development Lab		Designer: Jose Duron	IDLAB design #:
Board: WATCHMAN TC Prototype	Drawn By:	Approved By: Gary Varner	Revision: C
Sheet Title: FMC	A A		Variant: [No Variations]
			Modif. Date: 8/29/2018
			Sheet 2 of 7



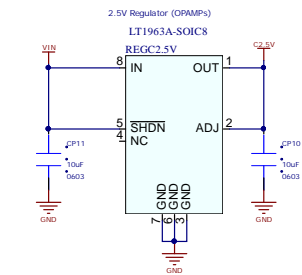
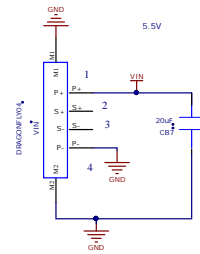
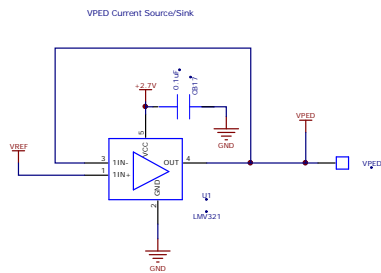
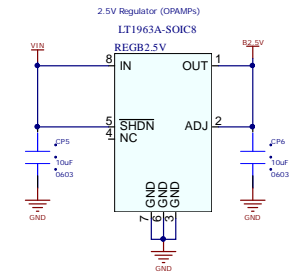
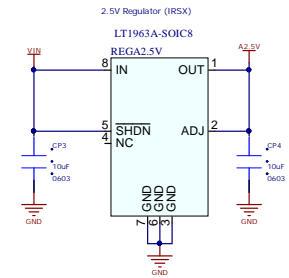
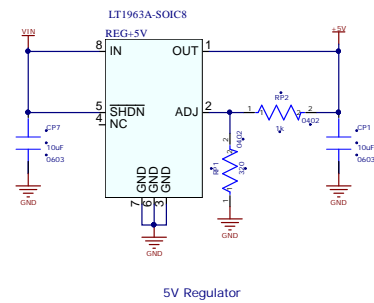
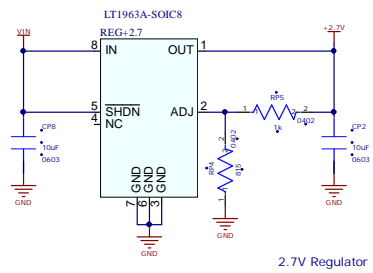

High Energy Physics Group, Instrumentation Development Lab	Designer: Jose Duron	IDLAB design #: C
Board: WATCHMAN TC Prototype	Drawn By: Approved By: Gary Varner	Revision: [No Variations]
Sheet Title: Power	A A	Modif. Date: 8/10/2018
		Sheet 3 of 7



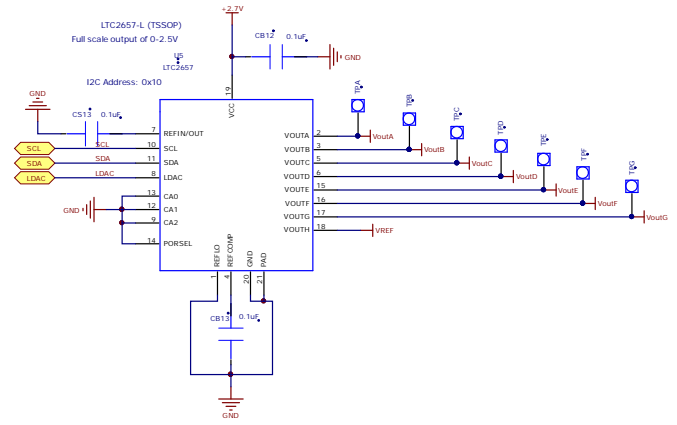
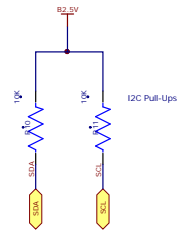

High Energy Physics Group, Instrumentation Development Lab	Designer: Jose Duron	IDLAB design #:	
Board: WATCHMAN TC Prototype	Drawn By:	Revision: C	
Sheet Title: Peripherals	Approved By: Gary Varner	Variant: [No Variations]	
	A A	Modif Date: 8/10/2018	
		Sheet 4 of 7	



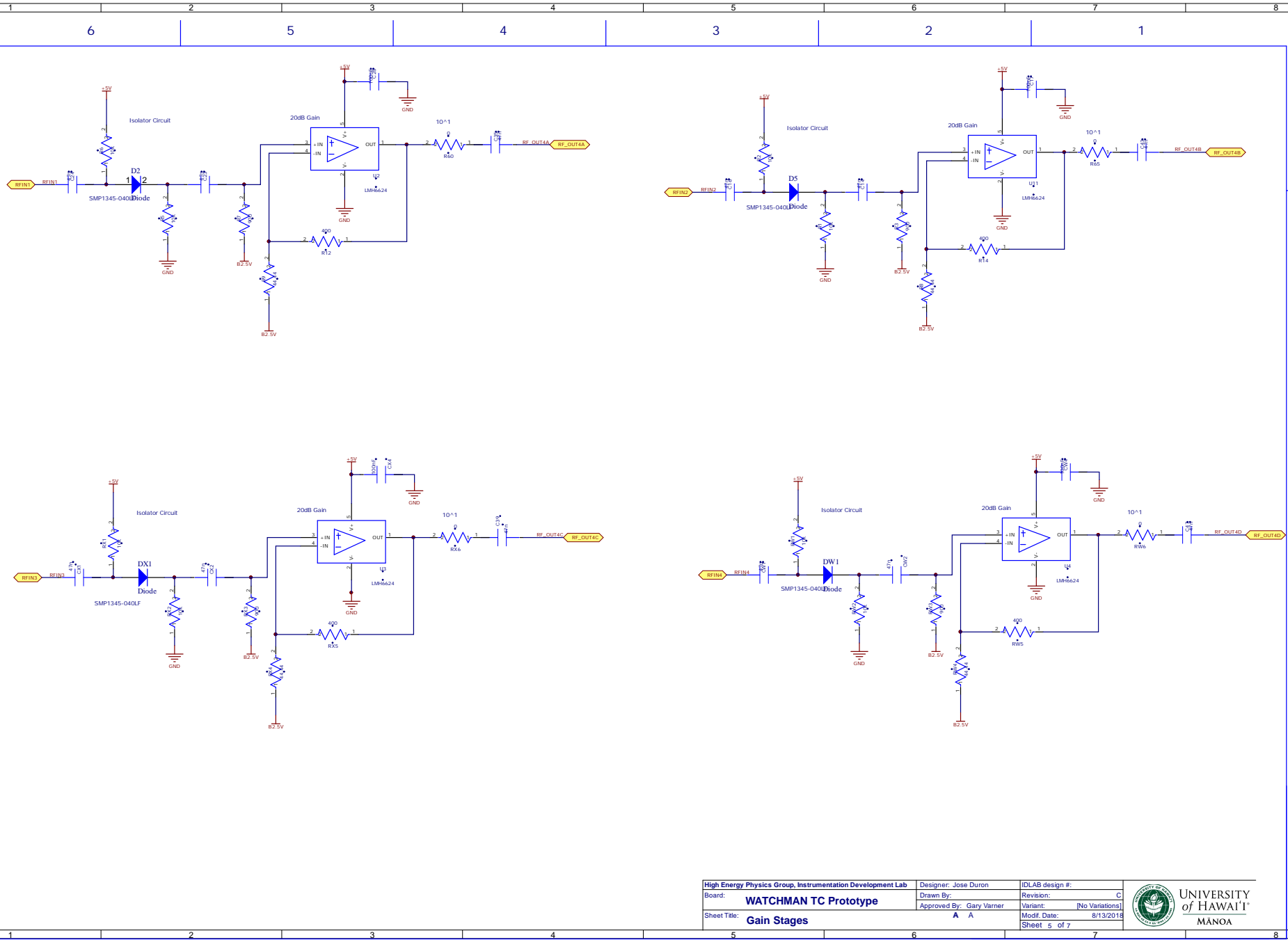

High Energy Physics Group, Instrumentation Development Lab	Designer: Jose Duron	IDLAB design #:
Board: WATCHMAN TC Prototype	Drawn By:	Revision: C
Sheet Title: Gain Stages	Approved By: Gary Varner	Variant: [No Variations]
	A A	Modif. Date: 8/13/2018
		Sheet 5 of 7



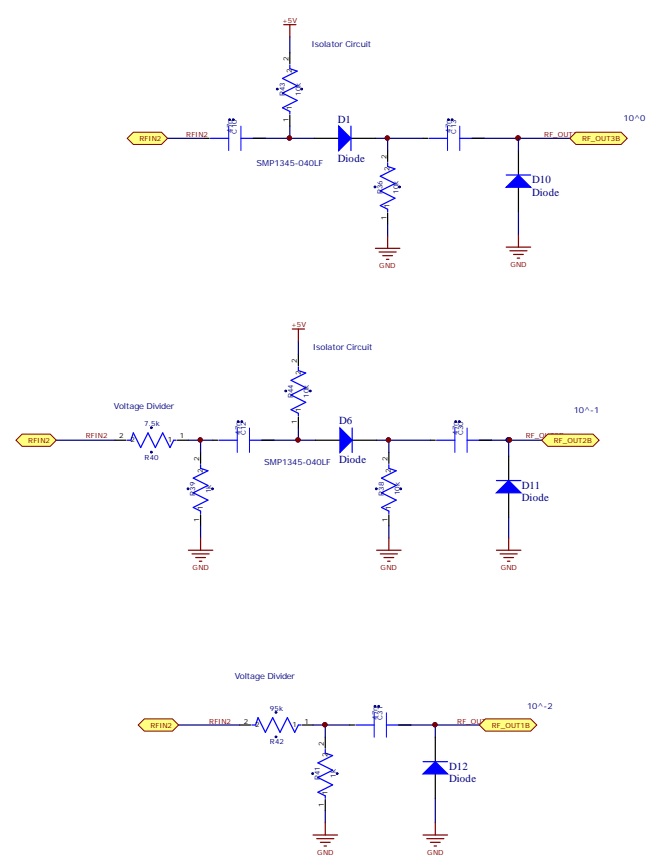
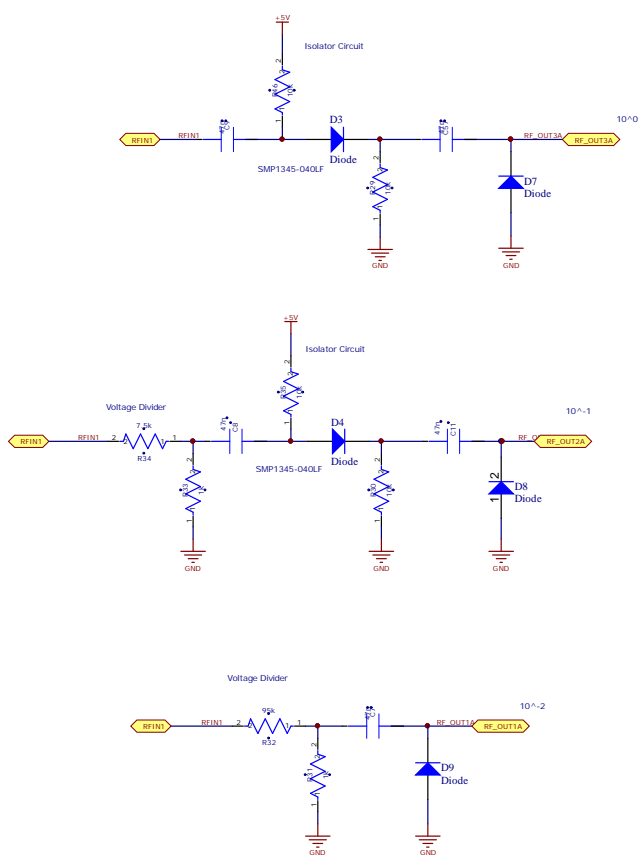

High Energy Physics Group, Instrumentation Development Lab		Designer: Jose Duron	IDLAB design #:
Board: WATCHMAN TC Prototype	Drawn By:	Approved By: Gary Varner	Revision: C
Sheet Title: Attenuation Stages A	A A	Variant: [No Variations]	Modif. Date: 8/13/2018
		Sheet 6 of 7	



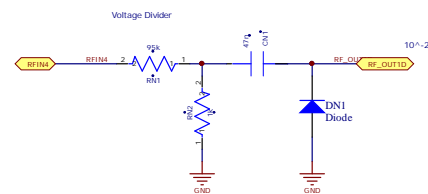
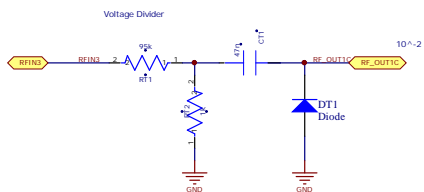
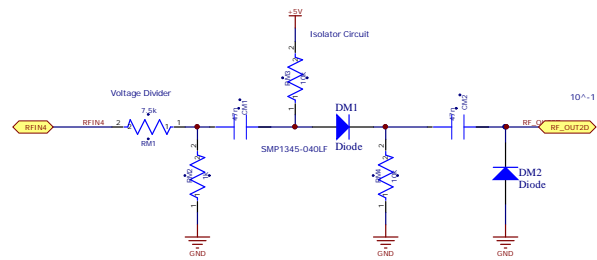
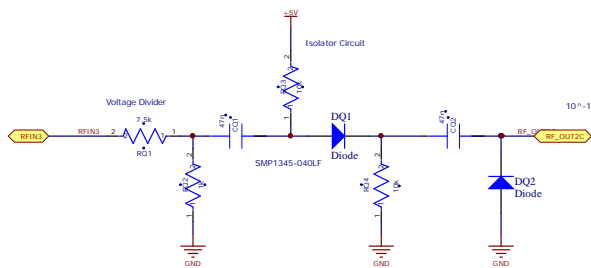
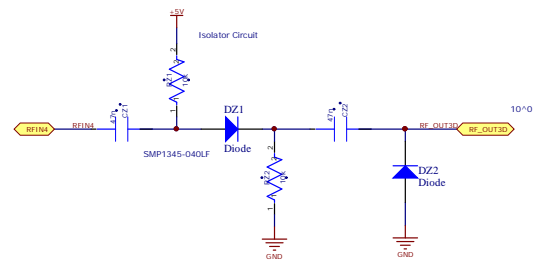
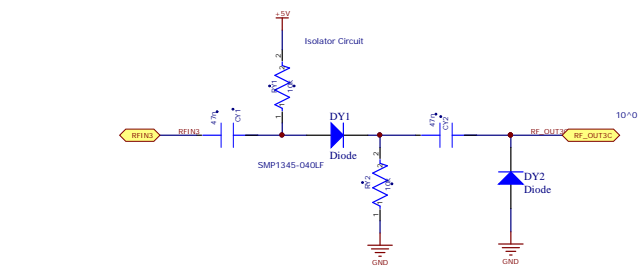

High Energy Physics Group, Instrumentation Development Lab

Board: WATCHMAN TC Prototype

Sheet Title: Attenuation Stages B

Designer: Jose Duron

Drawn By:

Approved By: Gary Varner

DLAB design #:

Revision: C

Variant: [No Variations]

Modif. Date: 8/13/2018

Sheet 7 of 7



UNIVERSITY
of HAWAII
MĀNOA

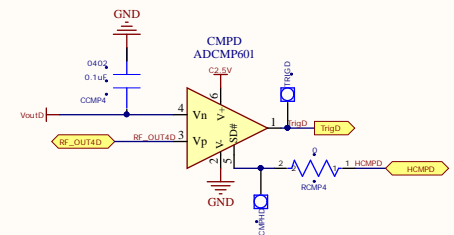
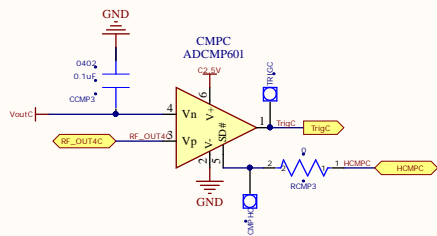
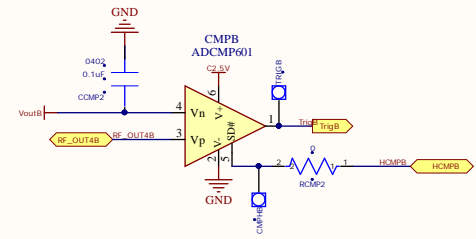
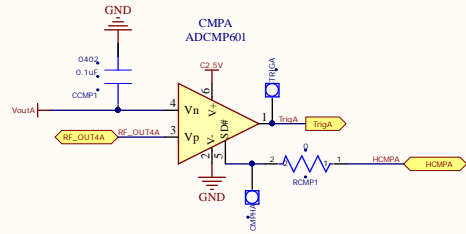

Title		
Size	Number	Revision
A3		
Date:	8/29/2018	Sheet of
File:	C:\Users\...Comparators.SchDoc	Drawn By:

View from Top side (Scale 1:1)

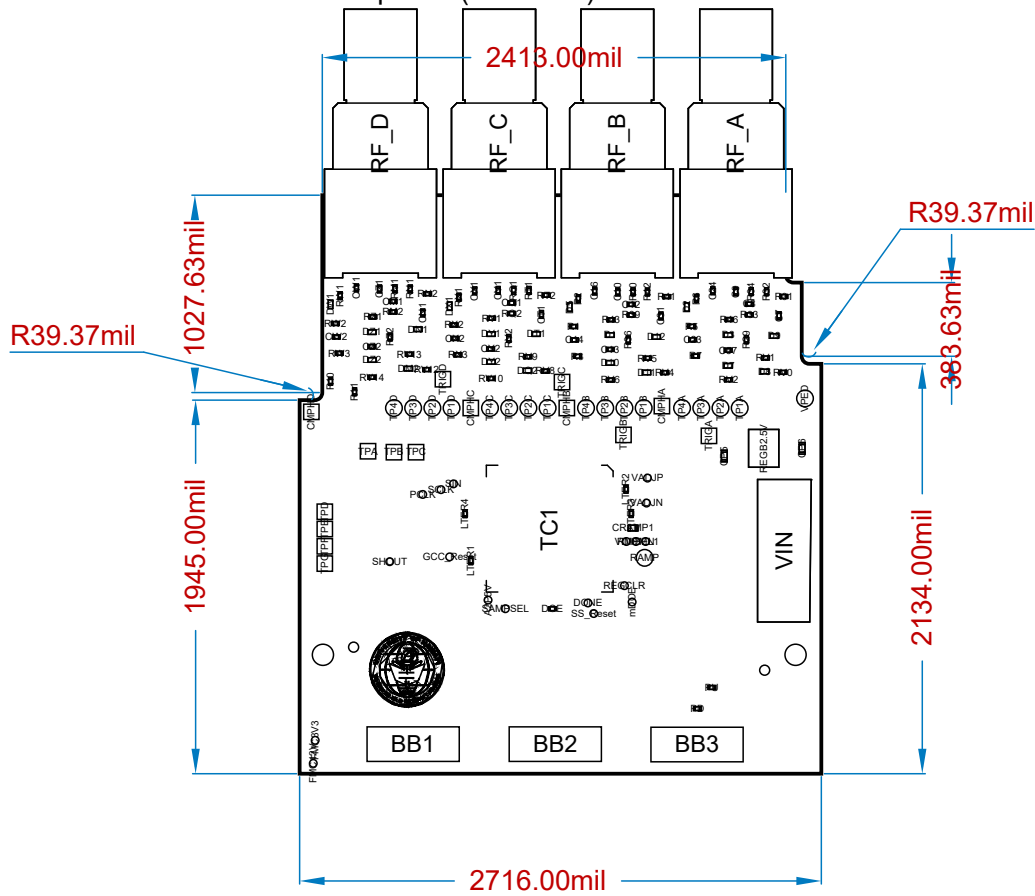

View from Bottom side (Scale 1:1)

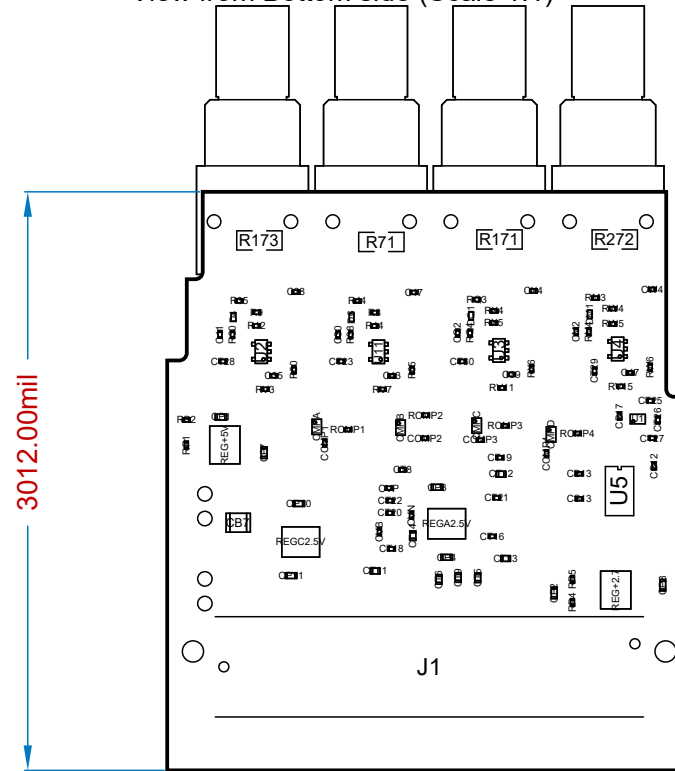

Layer Stack Legend

Material	Layer	Thickness	Dielectric Material	Type	Gerber
	Paste Mask Top			Paste Mask	GTP
	Silkscreen Top			Legend	GTO
Surface Material	Solder Mask Top	0.40mil	Solder Resist	Solder Mask	GTS
Copper	Top	1.38mil		Signal	GTL
Prepreg		5.91mil	FR-4	Dielectric	
Copper	GND	1.38mil		Internal Plane	GP1
Core		16.93mil	FR-4	Dielectric	
Copper	Vin/VPED	1.38mil		Internal Plane	GP2
Prepreg		5.91mil	FR-4	Dielectric	
Copper	Signal/C2.5V/5V	1.38mil		Signal	G1
Core		5.91mil	FR-4	Dielectric	
Copper	+2.5VA/B/2.7V	1.38mil		Internal Plane	GP3
Core		16.93mil	FR-4	Dielectric	
Copper	Bottom	1.35mil		Signal	GBL
Surface Material	Solder Mask Bottom	0.40mil	Solder Resist	Solder Mask	GBS
	Silkscreen Bottom			Legend	GBO
	Paste Mask Bottom			Paste Mask	GBP

Total thickness: 60.64mil

1

2

3

4

1

2

3

4

A

B

C

D

E

A

B

C

D

E

Drill Table

Symbol	Count	Hole Size	Plated	Hole Tolerance
△	159	10.00mil	Plated	None
☆	204	12.00mil	Plated	None
◇	18	19.69mil	Plated	None
▣	3	20.00mil	Plated	None
□	26	39.37mil	Plated	None
○	45	40.00mil	Plated	None
☆	2	44.88mil	Plated	None
⊗	2	60.00mil	Non-Plated	None
◇	8	78.74mil	Non-Plated	None
☆	4	83.07mil	Plated	None
⊕	2	118.11mil	Plated	None
473 Total				