

6

5

provides power to 4

3

2

1

E

E

D

D

C

C

B

B

A

A

320mV max dropout
A2.5V

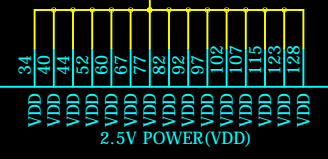
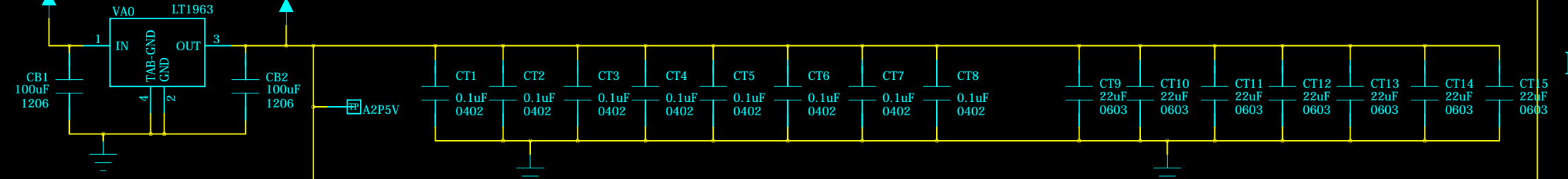

200pF for TARGET4
May be different for TARGET6

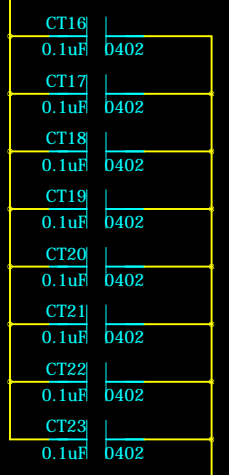
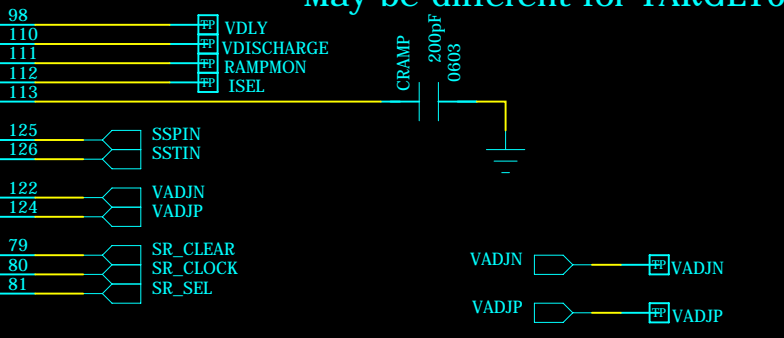
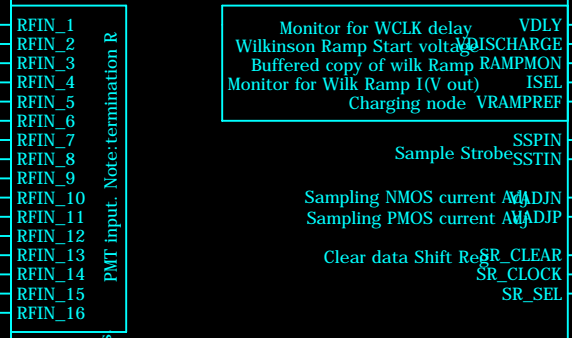
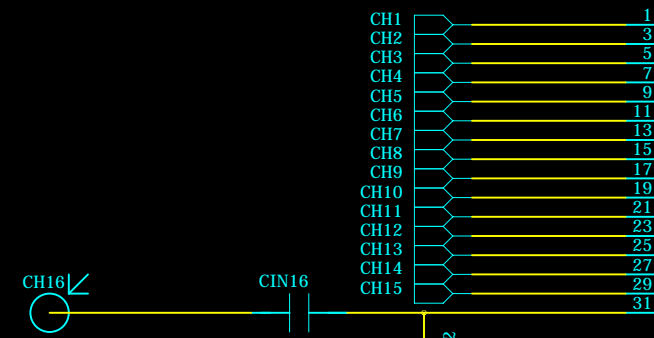
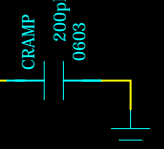

A2.5V

REGCLR

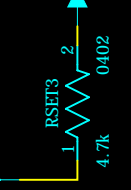

the pullup is so all the registers are cleared (even when FPGA not present)

Termination ref input, external, between pins

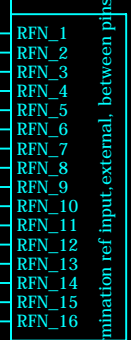

PMT input. Note: termination R

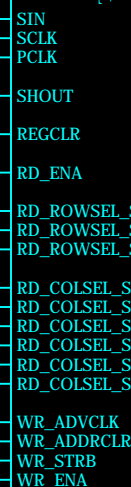

Start Wilkinson Conversion
Clear Wilkinson Counters



institution:	University of Hawaii at Manoa High Energy Physics Lab Instrumentation Development Lab
title:	T6 KLM Readout Daughtercard
revision:	B
IDLAB design #:	IDL_13_032
circuit design:	XS
PCB design:	XS
sheet #:	1 of 5
sheet description:	
date last modified:	6-28-2013

6

5

4

3

2

1

E

E

D

D

C

C

B

B

A

A

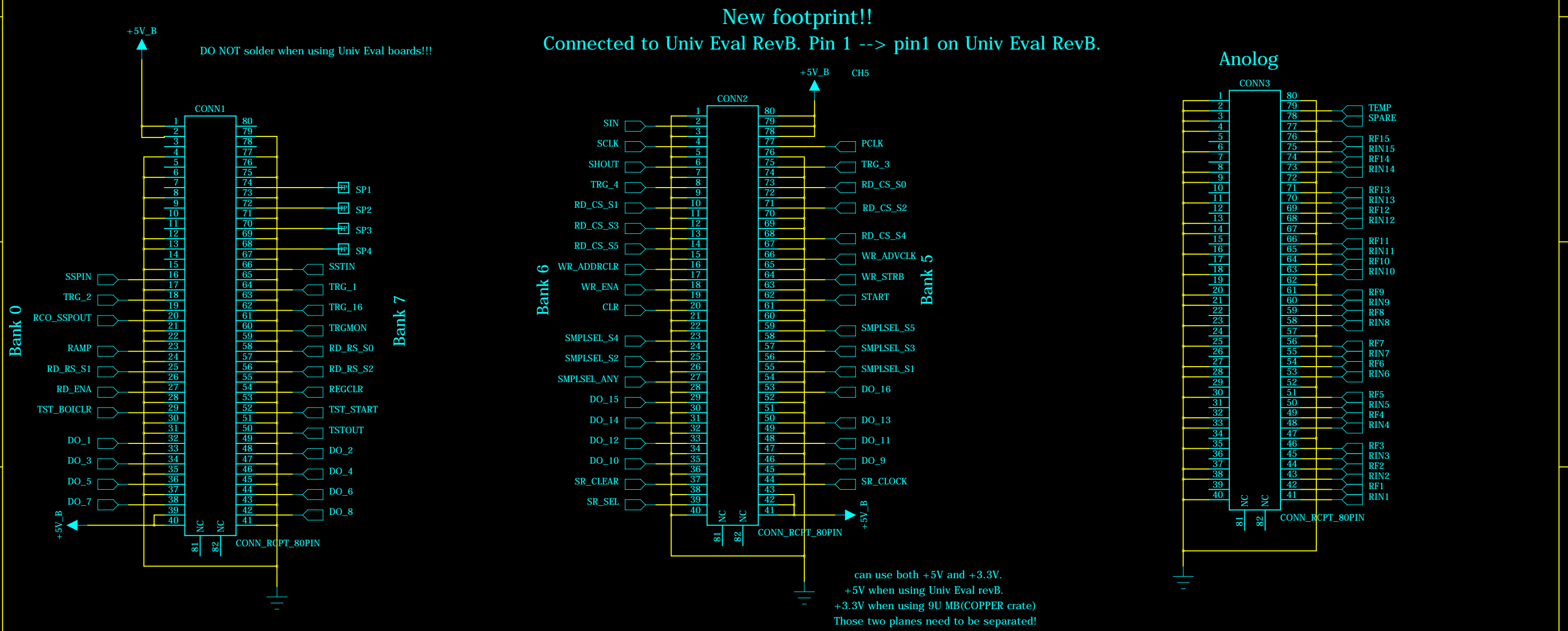

institution:	University of Hawaii at Manoa High Energy Physics Lab Instrumentation Development Lab
title:	T6 KLM Readout Daughtercard
revision:	B
IDLAB design #:	IDL_13_032
circuit design:	XS
PCB design:	XS
sheet #:	2 of 5
sheet description:	
date last modified:	6-28-2013

6

5

4

3

2

1

E

E

LM317 input voltage: 4.2V~37V
provides pedestal voltage for ASIC
Specified 1.5A output current

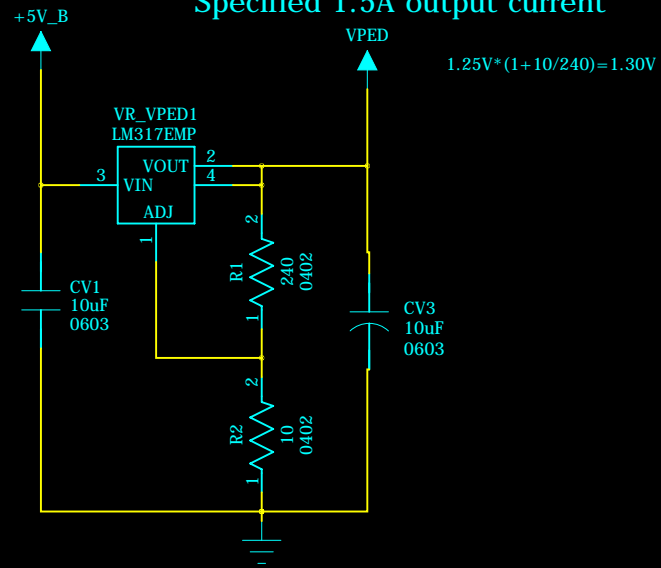

LM317 input voltage: 4.2V~37V
provides ~1.3V for preamps
Specified 1.5A output current

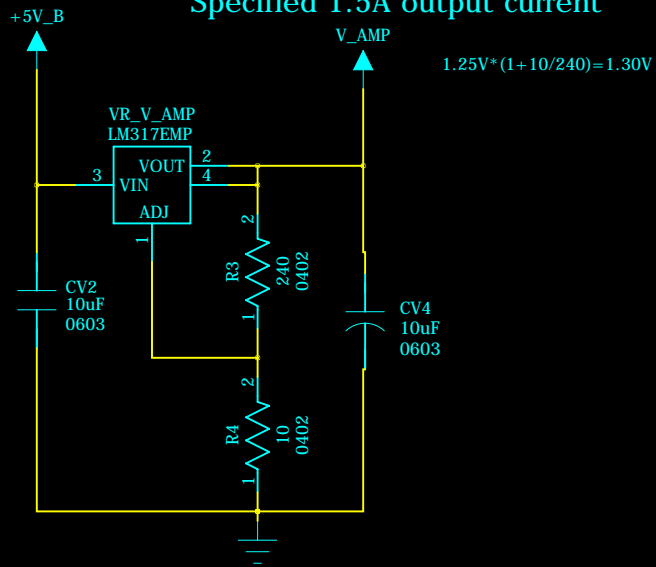

D

D

C

C

B

B

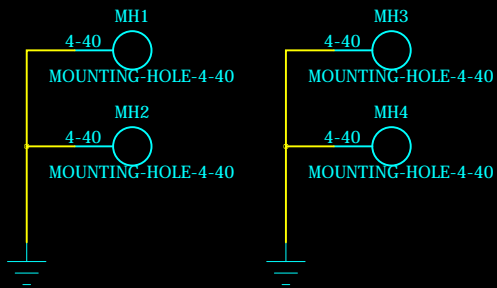

A

A

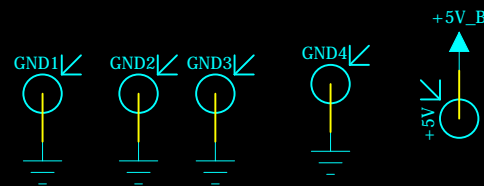

institution:	University of Hawaii at Manoa High Energy Physics Lab Instrumentation Development Lab
title:	T6 KLM Readout Daughtercard
revision:	B
IDLAB design #:	IDL_13_032
circuit design:	XS
PCB design:	XS
sheet #:	3 of 5
sheet description:	
date last modified:	6-28-2013

6

5

4

3

2

1

E

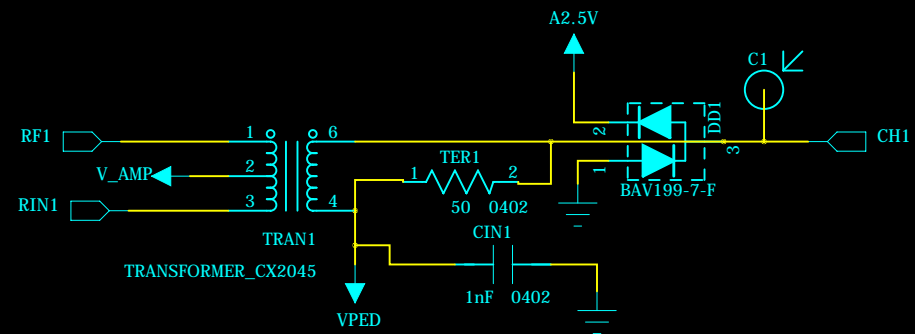

E

D

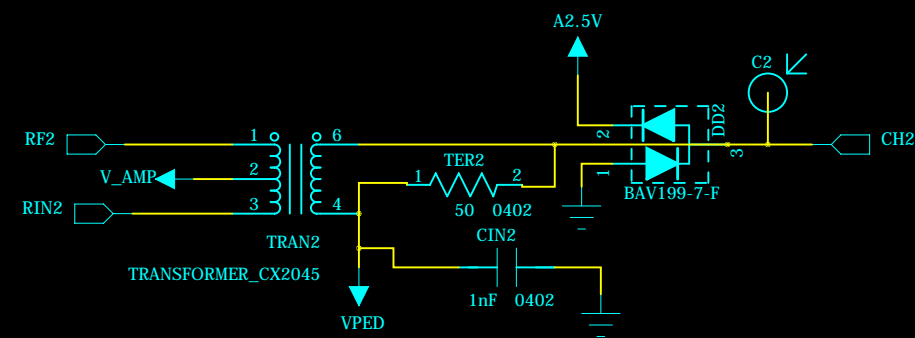

D

C

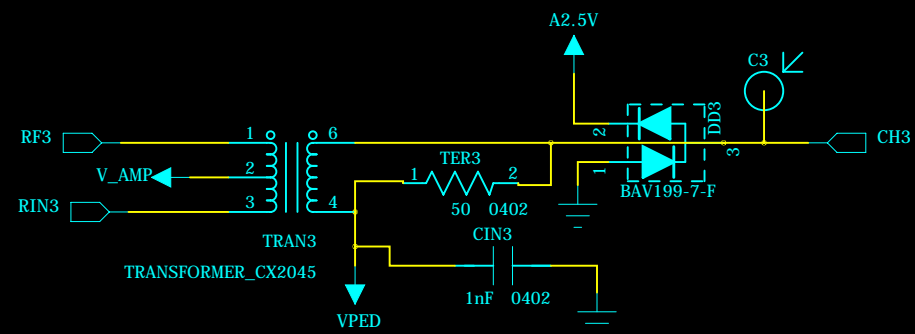

C

B

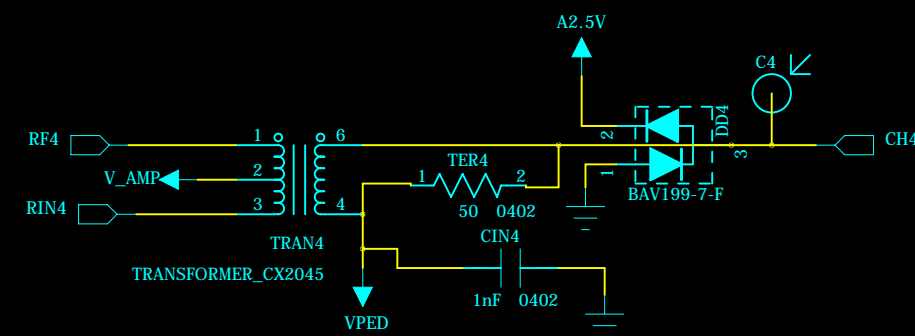

B

A

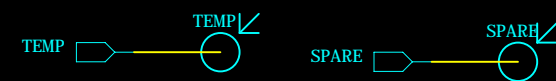

A

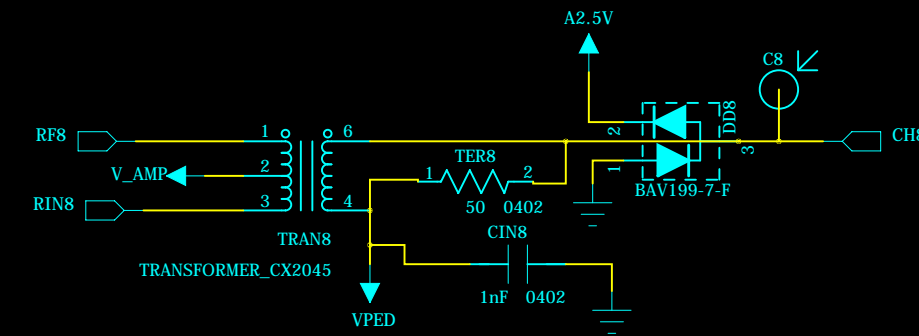
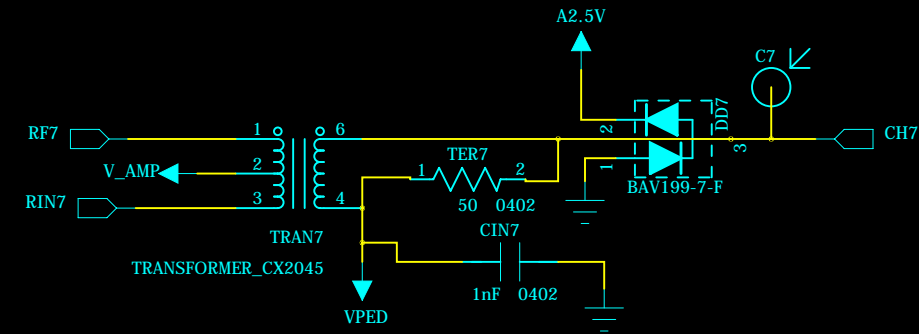
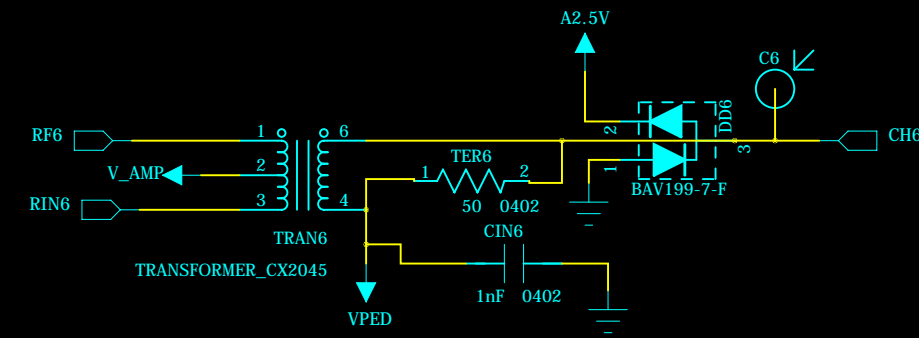
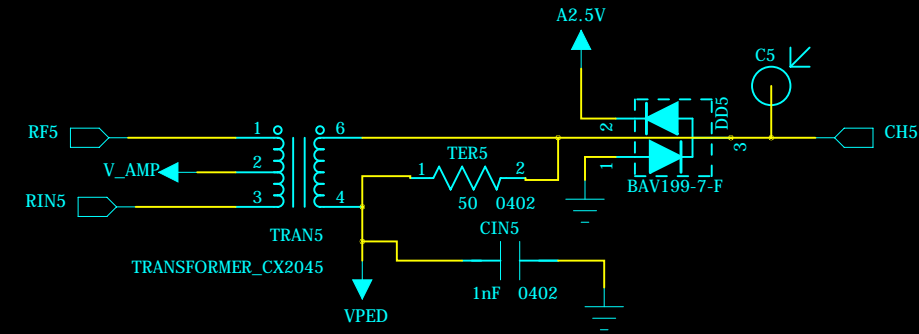

institution: University of Hawaii at Manoa
High Energy Physics Lab
Instrumentation Development Lab

title: T6 KLM Readout Daughtercard
revision: B
IDLAB design #: IDL_13_032
circuit design: XS
PCB design: XS

sheet #: 4 of 5
sheet description:
date last modified: 6-28-2013

6

5

4

3

2

1

E

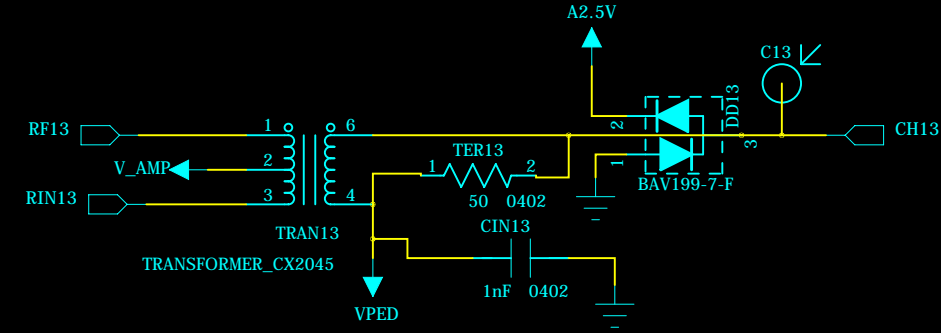
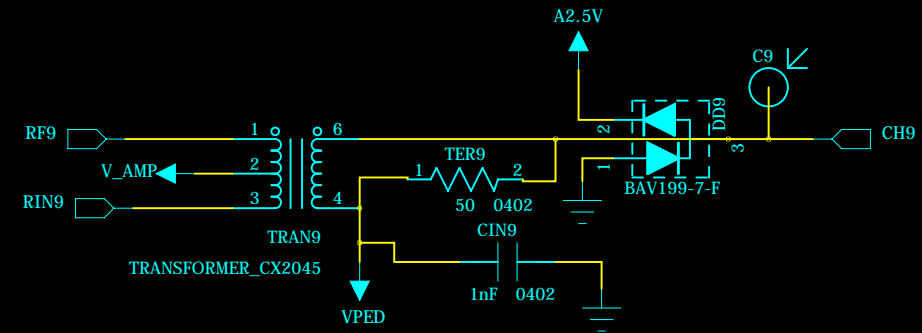

D

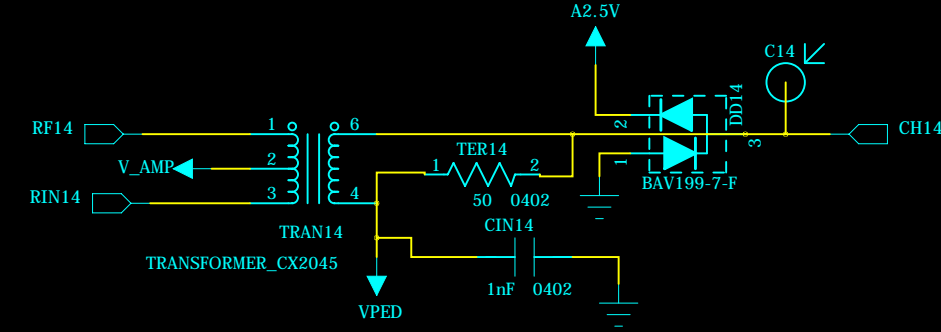
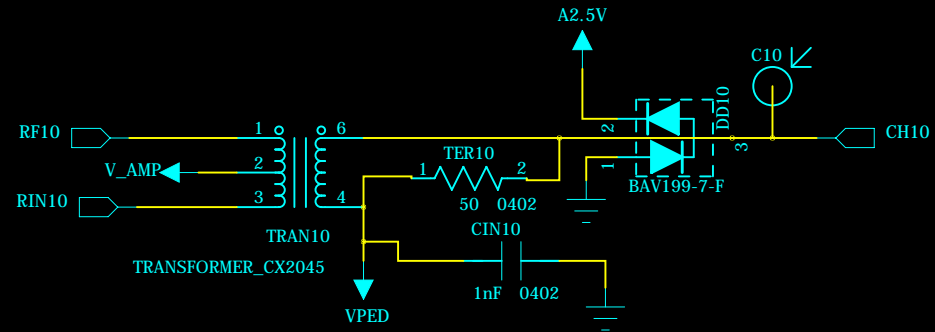

C

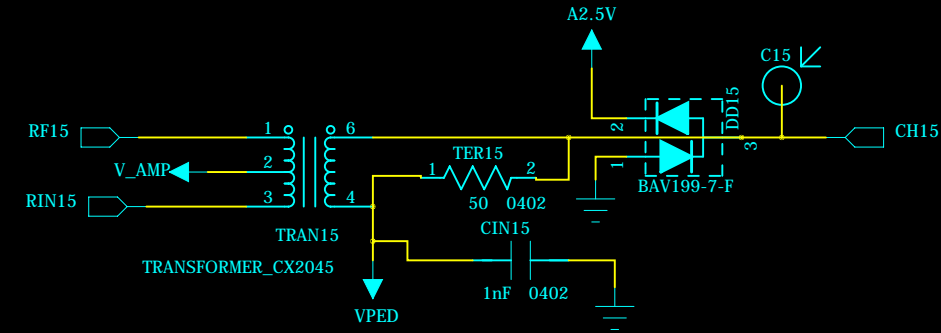
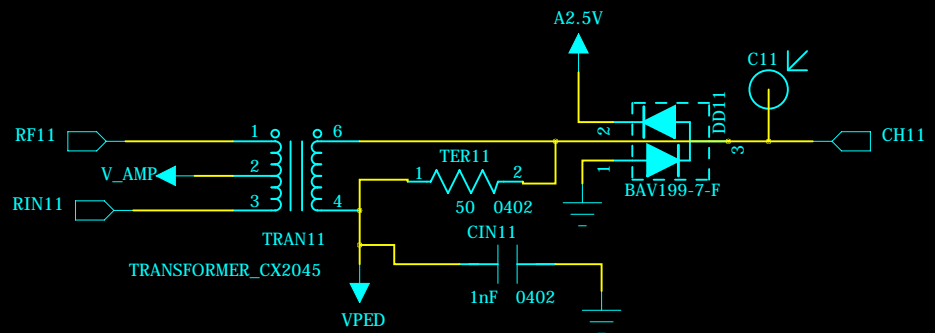

B

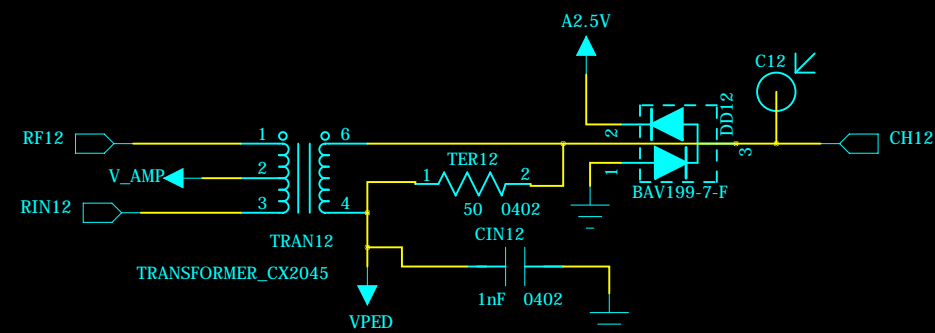

A

institution: University of Hawaii at Manoa
High Energy Physics Lab
Instrumentation Development Lab

title: T6 KLM Readout Daughtercard
revision: B
IDLAB design #: IDL_13_032
circuit design: XS
PCB design: XS

sheet #: 5 of 5
sheet description:
date last modified: 6-28-2013

E

D

C

B

A