



January 20, 2004

RF and longitudinal stability for Super-PEP-II

D. Teytelman

A. Novokhatski, J. Seeman



Outline

- 1 Introduction to coupled-bunch longitudinal instabilities
- 2 Bunch-by-bunch longitudinal feedback and its limitations
- 3 Longitudinal stability in a storage ring with high beam loading
- 4 Low-level RF feedback - impedance reduction
- 5 RF options for Super-PEP-II: longitudinal stability studies
- 6 Low-level RF options for better impedance control
- 7 Summary

Coupled-bunch instabilities: eigenmodes and impedances

For an even fill pattern the bunch motion can be easily projected into the even-fill eigenmode (EFEM) basis. For N coupled harmonic oscillators (bunches) there are N normal modes.

Longitudinal modal eigenvalues are given by

$$\Lambda_l = -d_r + i\omega_s + \underbrace{\frac{\alpha e f_{\text{rf}}}{2E_0 v_s}}_{\text{Accelerator parameters}} \underbrace{I_0}_{\text{Beam current}} \underbrace{Z^{\text{eff}}(l\omega_{\text{rev}} + \omega_s)}_{\text{Aliased impedance}}$$

$$Z^{\text{eff}}(\omega) = \sum_{p=-\infty}^{\infty} \frac{(p\omega_{\text{rf}} + \omega)}{\omega_{\text{rf}}} F(p\omega_{\text{rf}} + \omega) Z(p\omega_{\text{rf}} + \omega)$$

Real part of the eigenvalue is the exponential growth rate, imaginary part - undamped natural frequency.

Growth rate is proportional to beam current. Above some threshold current the system is unstable.

Two ways to fight the instabilities: lower the impedance via passive or active techniques or apply feedback damping

Form factor $F(\omega) = e^{-(\omega\sigma_z)^2}$ defines roll-off of the aliased impedance due to non-zero bunch length.

Coupled-bunch instabilities: parametric dependencies

For a constant driving impedance instability growth rate is:

- Proportional to $\sqrt{f_{\text{rf}}}$
- Proportional to $\sqrt{\alpha}$
- Proportional to $\frac{1}{v_s}$, thus scales as $\frac{1}{\sqrt{V_{\text{rf}}}}$
- Shorter bunch length increases form factor $F(\omega)$ at high frequencies, thus physical impedances at those frequencies become more important.

Why are the absolute values of the growth rates important? If we are using feedback to control coupled-bunch instabilities couldn't we just raise the gain till the beam is stable?

To answer these questions we need to look at the limitations of such feedback systems.

Limits on achievable LFB control

Instability growth rates

- Maximum stable loop gain - depends on controller design, total loop delay.
- Maximum usable loop gain - gain that provides the largest damping. Depends on the same parameters as the maximum stable gain, but is significantly lower.
- Feedback systems in PEP-II (both LER and HER) are currently running near maximum usable gain to control fundamental-driven modes.
- Noise floor at the ADC - depends on RF-driven noise level, front-end electronics design
- Transient sensitivity - effect of injection and RF transients on longitudinal control. The sensitivity can be reduced by increasing kicker voltage.

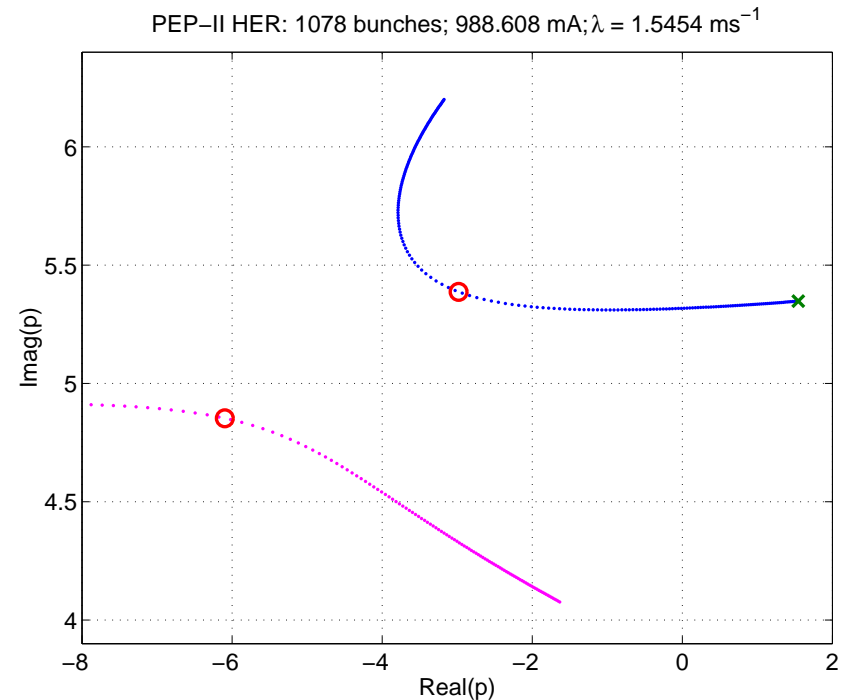

For a conventional system the minimum group delay is one turn.

From experimental measurements at multiple machines we determined that for a downsampled system the controllable ratio of the oscillation frequency to the growth rate (ω_s/λ) is in the range from 15-30. Note that higher synchrotron frequency allows control of faster growth rates.



Effects of the gap transient

Different bunches see different RF voltage slopes and, therefore, have differing synchrotron tunes and bunch lengths - normally a negligible effect.

In the LFB front-end the transient appears as constant DC offsets of individual bunches. This has several consequences:

- Amplitude of the gap transient cannot exceed the full-scale peak-to-peak range of the LFB phase detector (30 degrees@RF for 6th RF harmonic detection).
- Largest expected gap transient amplitude sets the feedback front-end gain since we need to properly detect AC motion for the bunches at the extremes of the transient.
- Phase detector gain rolls off as $\cos(M\phi)$ where M is the detection harmonic

In the back-end of the LFB the effects of the gap transient are less severe. The main effect is the gain roll off in the kicker at the extremes of the transient, however the effect is smaller due to the lower back-end center frequency.

Synchronous gap transient: an example

PEP-II Low Energy Ring at 1553 mA

Four RF cavities are powered and two are parked.

Synchronous phase transient includes effects of both active and parked cavities. Cavities parked between 2 and 3 revolution harmonics add oscillatory behavior to the transient.

Overall transient is 23.5 degrees peak-to-peak - this leaves little room for phase drifts.

Bunches at the beginning of the train are offset by 14 degrees! That corresponds to almost 20 dB gain reduction.

In this configuration we keep the tail of the train closer to zero degrees so that the feedback gain at the tail is higher. Since the driving term is larger at the tail of the train we need more gain there.

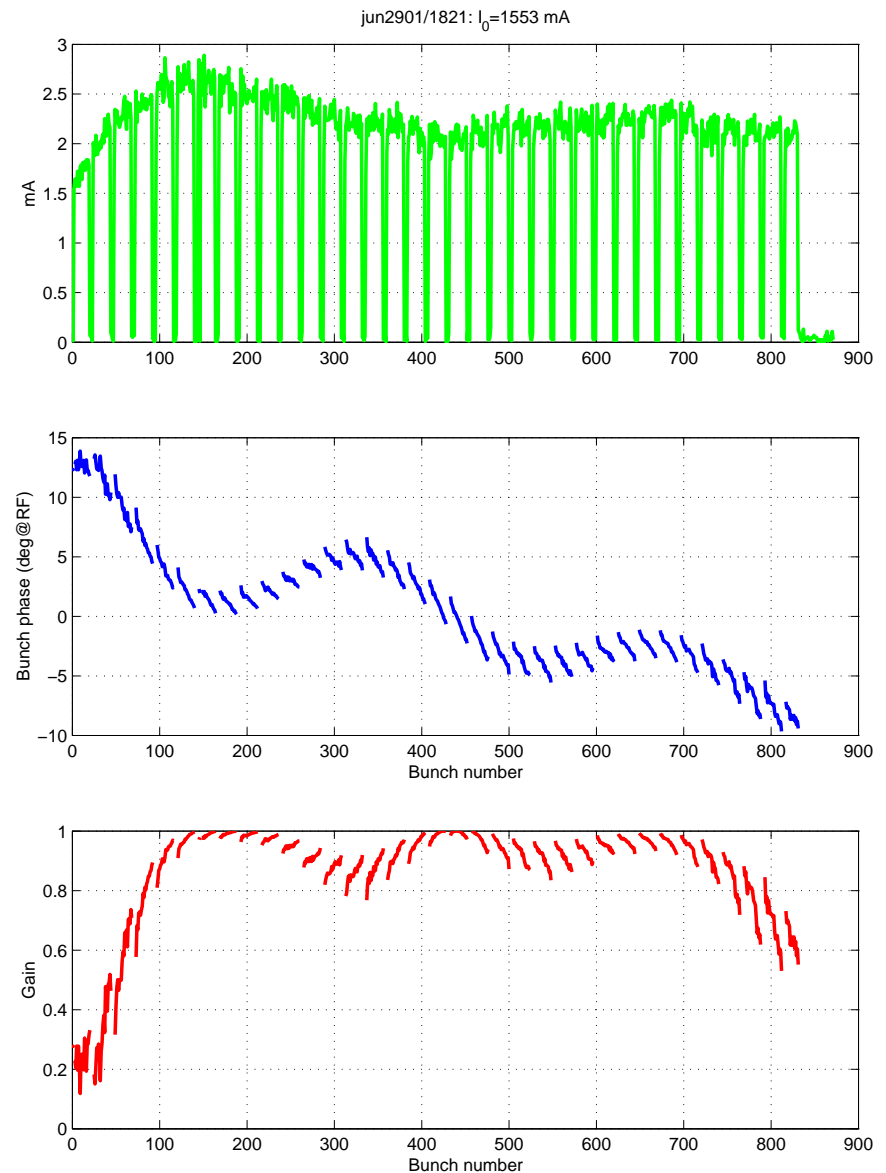



Bunch-by-bunch feedback technology for Super-PEP-II

We have started design of a general-purpose feedback signal processor (Gboard). The processor envisioned as a single VME64X module will support:

- Transverse bunch-by-bunch control at KEKB, PEP-II, SuperKEKB, Super-PEP-II and others
- Longitudinal bunch-by-bunch control at KEKB, PEP-II, SuperKEKB, Super-PEP-II, et al
- Transient diagnostics features (e.g. instability growth/damping rate measurements)
- Fast bunch and beam instrumentation (e.g. bunch by bunch current monitor, tune monitor, gap transient/synchronous phase measurement)
- Bunch spacings down to 0.66 ns - sampling at 1.5 GHz.

The baseband processing channel is useful for transverse processing using two pickups (e.g. quadrature pickups) or single pickup approaches (filter adjusts phase shift of kick)

The fast sampling rate can implement two sample/bunch processing for true I&Q front end processing which would improve operational stability of bunch-by-bunch feedback systems.

This core function is general purpose, and re-configurable into a variety of signal processing and instrument functions - the reconfigurable Xilinx FPGAs define the exact algorithm. With the 1.5 GHz sampling rate this core function would be applicable to several other accelerator processing needs, including NLC damping rings, numerous existing and proposed light sources, and several recirculating linac proposals.



Gboard Processing Channel Specifications

The basic structure of the processing channel is a high speed multiplexed parallel processor, with single input and output channels. The architecture is optimized to do cyclic processing, as in a storage ring, where the computation of the output for channel N depends on the past history of channel N. However, the re-configurable Xilinx gate arrays could support a variety of functions, including a prompt high-speed feedback/feedforward channel, consistent with the pipeline delay in the A/D and processing stages.

- Support arbitrary even harmonic numbers
- Independent processing for all bunches on all turns - required for transverse feedback
- Diagnostic memory capable of holding 20 ms of data at the full rate
- Support downsampled processing - reuse the hardware to get longer filters
- Support downsampling for diagnostics for studying slow events
- Support long FIR or IIR filters

For the Advanced B Factory with 476 MHz RF frequency the Gboard would support longitudinal and transverse bunch-by-bunch processing using 2 samples per bunch to eliminate sensitivity to gap transients and beam or reference phase shifts.

With the RF frequency of 952 MHz the Gboard would utilize traditional amplitude (transverse) and phase (longitudinal) detectors to observe bunch motion.

Bunch-by-bunch feedback summary

Design work has been started on a high-speed processing channel necessary for controlling longitudinal and transverse coupled-bunch instabilities in the proposed 10^{35} - 10^{36} cm⁻²s⁻¹ machines.

Longitudinal bunch-by-bunch feedback has a fundamental loop delay limit on the controllable instability growth rates.

In the design of the new machines careful attention must be paid to keeping the longitudinal growth rates below that limit.

A similar limit exists for the transverse coupled-bunch feedback systems, however the limit is less severe due to the high betatron oscillation frequency.

Synchronous phase transient reduces the effective feedback gain for parts of the bunch train and is best kept low.

Fundamental impedance of RF cavities and instabilities

Consider only the fundamental mode of the RF cavity - non-negligible impedance only near ω_{rf}

$$\Lambda_l \approx \Lambda^0 + \frac{\pi \alpha e f_{\text{rf}}^2}{E_0 h \omega_s} I_0 [Z(\omega_{\text{rf}} + l\omega_{\text{rev}} + \omega_s) - Z^*(\omega_{\text{rf}} - l\omega_{\text{rev}} - \omega_s)]$$

The growth rate is proportional to the difference of impedance real part at the upper synchrotron sideband of the appropriate revolution harmonic and the lower sideband of the opposite rev. harmonic.

When cavity detuning is near $\omega_{\text{rev}} - \omega_s$ peak of the cavity impedance (real) excites eigenmode -1.

For PEP-II beam loading is high enough that RF cavities must be detuned beyond first revolution harmonic. The worst-case growth rate for mode -1 is 30 ms^{-1} . Compare $33 \mu\text{s}$ growth time to $185 \mu\text{s}$ synchrotron period!

Unlike higher-order mode resonances the fundamental mode cannot be suppressed by passive measures and requires active feedback.

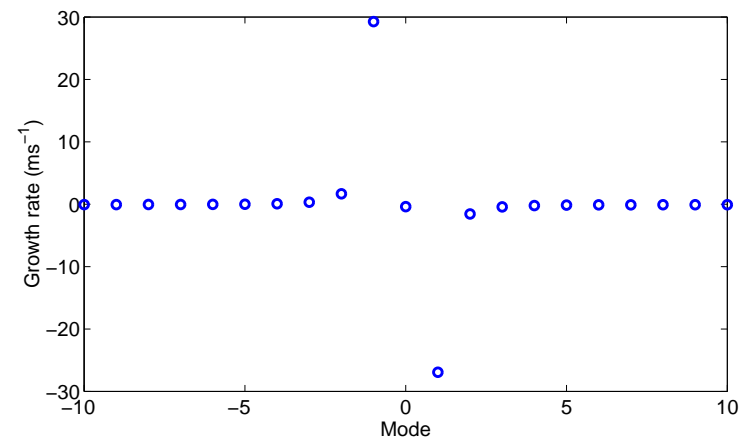
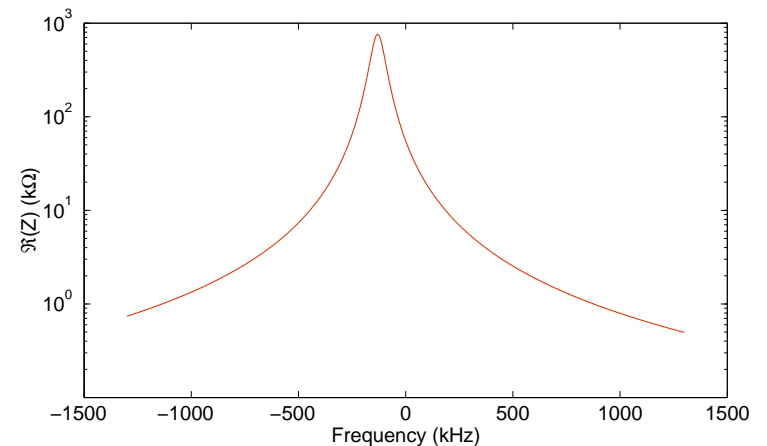

PEP-II fast impedance control loops: topology

The most important elements of the impedance controlling feedback loops are shown. The direct feedback loop uses the cavity vector sum signal (a complex signal), scaled in magnitude and rotated in phase as an input to a reference summing node. The comb loop (a periodic IIR filter) uses the direct loop output via the comb filter, scaled and rotated, as a summing input.

The overall action of this feedback topology is to keep the combined direct and comb outputs exactly equal to the station reference - any error signal is amplified via the klystron and cavity path.

The overall station cavity magnitude and phase are set via this reference. Many other important elements (such as lead/lag compensation to improve the loop stability margin, an integrator for high DC gain, etc.) are not shown.

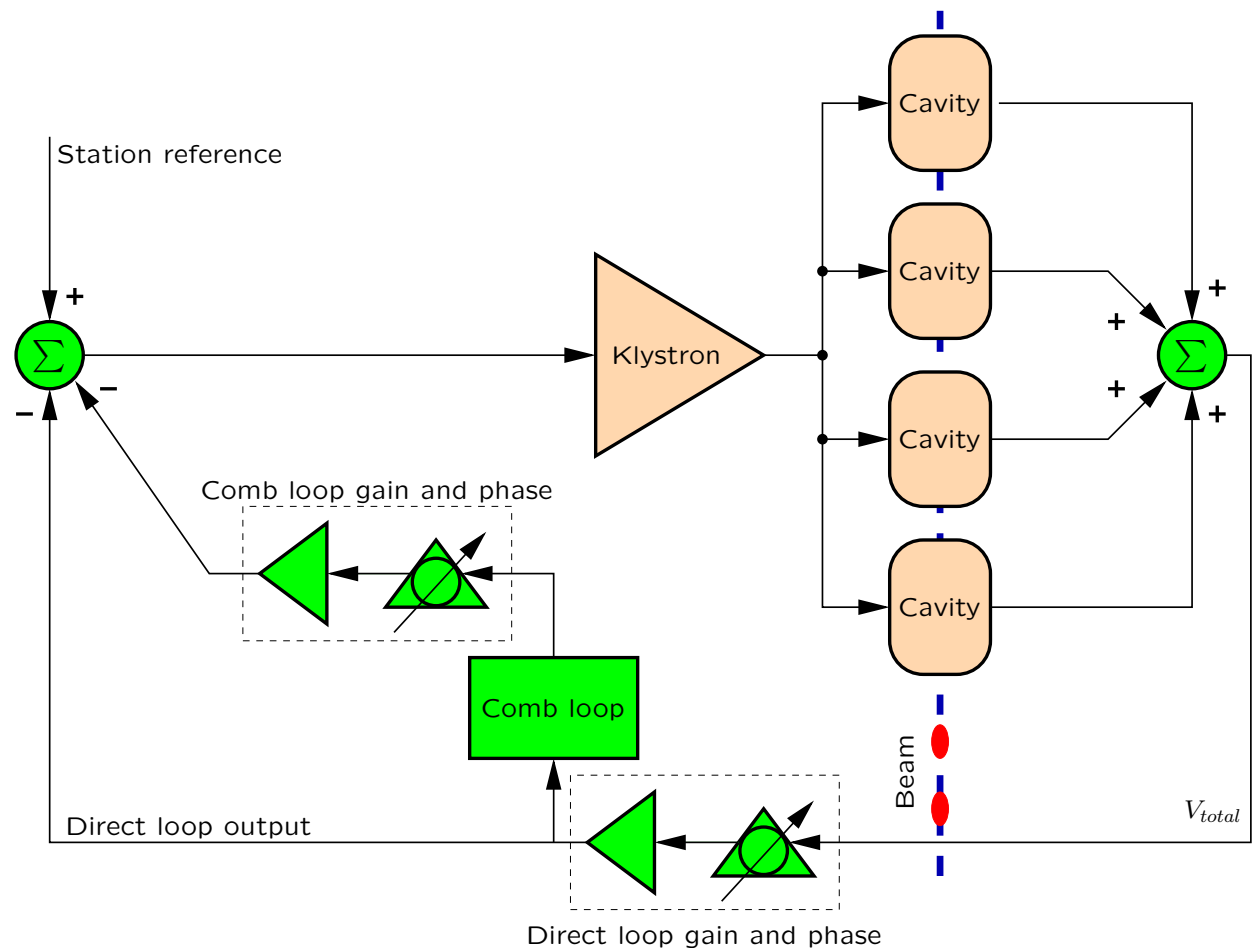

PEP-II low-level RF feedback: impedances and growth rates

Two feedback loops are used in PEP-II to reduce the fundamental impedance acting on the beam: direct and comb.

Direct loop is a proportional feedback loop around the cavity. Closing the direct feedback loop reduces the effective impedance seen by the beam and lowers the growth rates. However the rates are still too high.

To reduce the growth rates further we add the comb filter with narrow gain peaks at synchrotron sidebands.

Expected growth rates shown here are computed using a linear transfer function model of the RF feedback system.

According to the linear model the growth rate reduction is two orders of magnitude, from 30 to 0.35 ms^{-1}

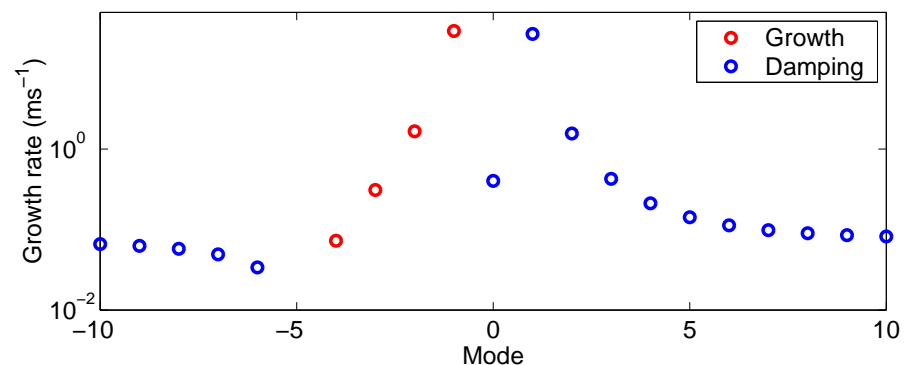
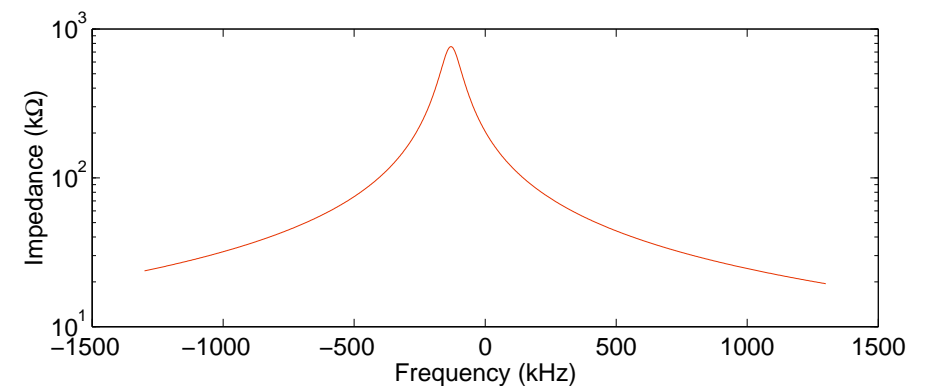
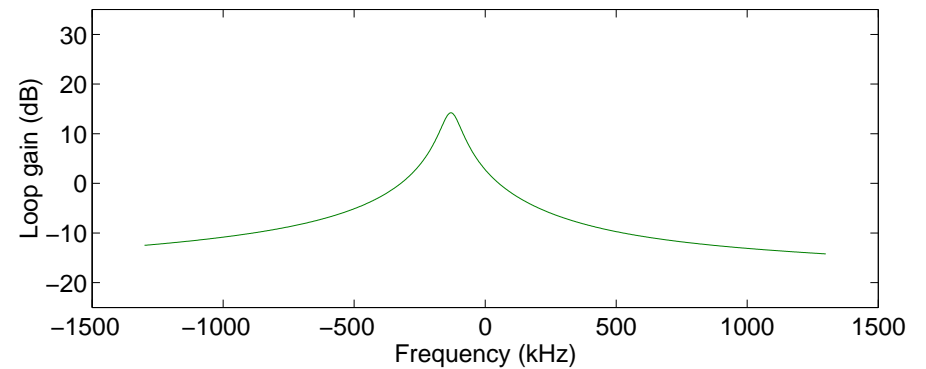

PEP-II low-level RF feedback: impedances and growth rates

Two feedback loops are used in PEP-II to reduce the fundamental impedance acting on the beam: direct and comb.

Direct loop is a proportional feedback loop around the cavity. Closing the direct feedback loop reduces the effective impedance seen by the beam and lowers the growth rates. However the rates are still too high.

To reduce the growth rates further we add the comb filter with narrow gain peaks at synchrotron sidebands.

Expected growth rates shown here are computed using a linear transfer function model of the RF feedback system.

According to the linear model the growth rate reduction is two orders of magnitude, from 30 to 0.35 ms^{-1}

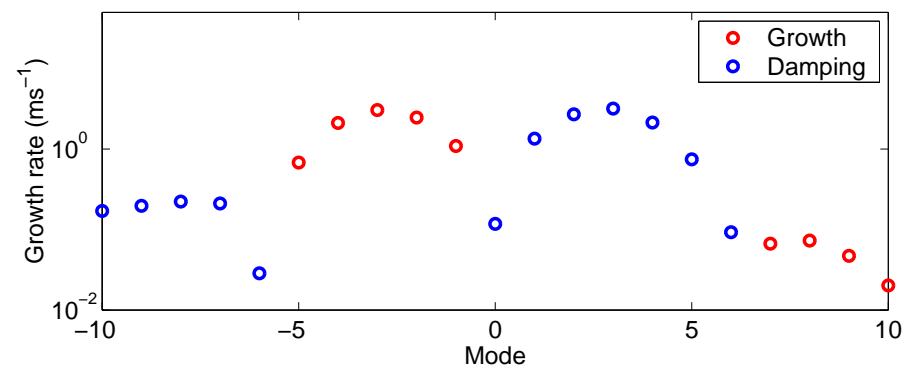
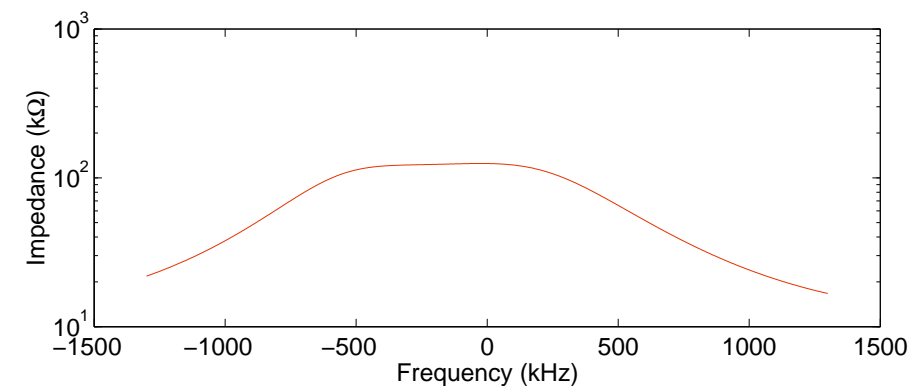
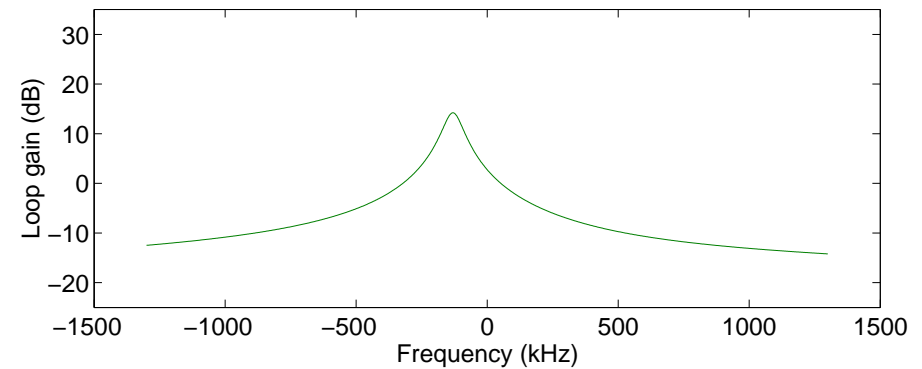

PEP-II low-level RF feedback: impedances and growth rates

Two feedback loops are used in PEP-II to reduce the fundamental impedance acting on the beam: direct and comb.

Direct loop is a proportional feedback loop around the cavity. Closing the direct feedback loop reduces the effective impedance seen by the beam and lowers the growth rates. However the rates are still too high.

To reduce the growth rates further we add the comb filter with narrow gain peaks at synchrotron sidebands.

Expected growth rates shown here are computed using a linear transfer function model of the RF feedback system. According to the linear model the growth rate reduction is two orders of magnitude, from 30 to 0.35 ms^{-1}

PEP-II residual impedances:

LER: 256 $\text{k}\Omega$ with 6 cavities

HER: 900 $\text{k}\Omega$ with 26 cavities

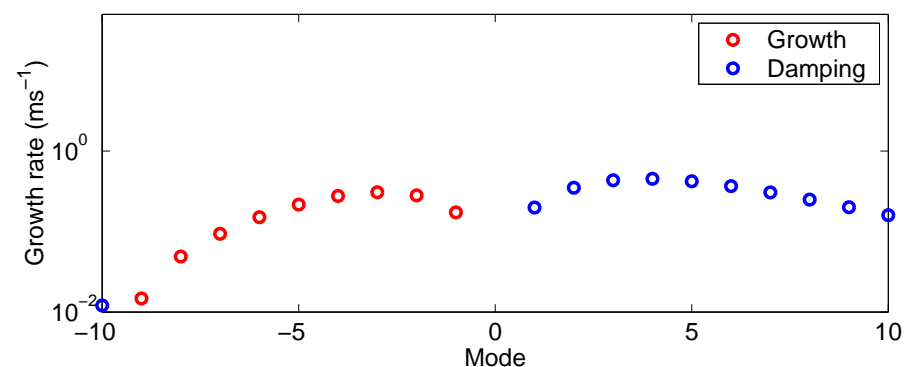
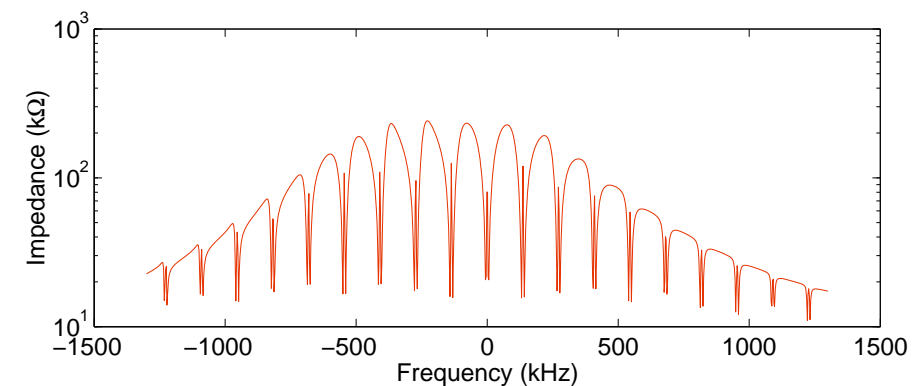
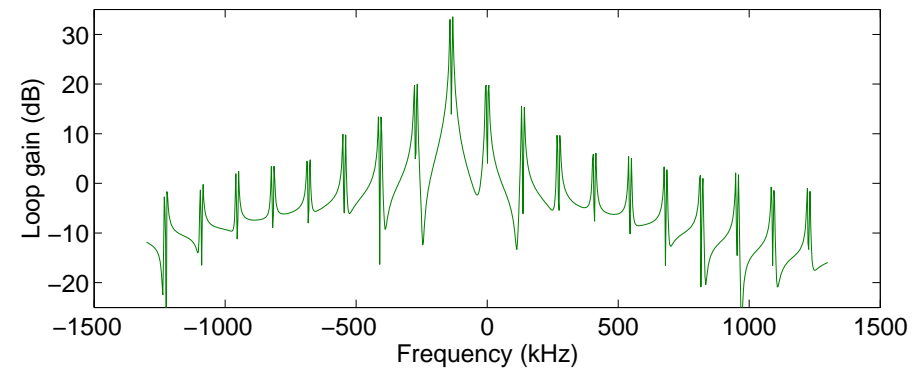

Super-PEP-II RF studies

Several assumptions:

- RF system is operated with zero loading angle - cavities are always tuned for minimal reflected power.
- RF is set up with a large overvoltage factor, so that synchronous phase angle ϕ_B is close to 180° . A reasonable assumption given the short proposed bunch lengths.
- Generator couples 500 kW into each cavity

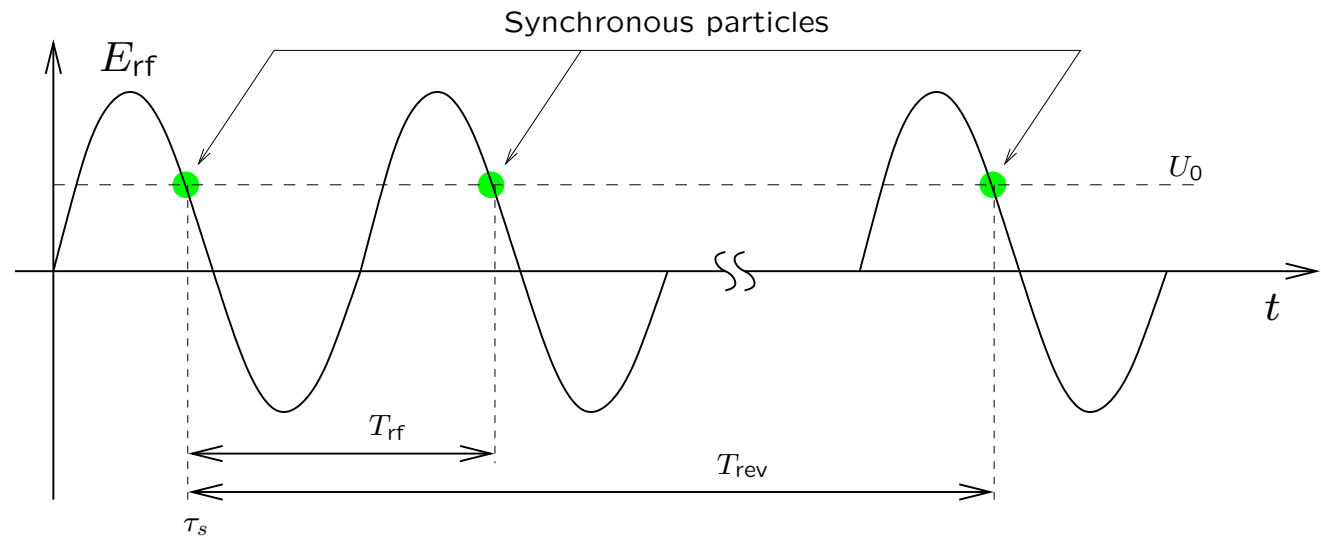

I will consider two advanced B factory parameter sets (LER only):

RF frequency, MHz	Maximum beam current, A	RF voltage, MV	Beam power, MW
476	11	35	22.5
952	23	31	19.8

Can we keep cavity detuning below one revolution harmonic?

We start from answering the following question: can an RF system be designed so that the cavities that are detuned by less than a revolution harmonic at the highest beam current? Doing so greatly reduces the requirements to the RF feedback and bunch-by-bunch feedbacks.

Cavity detuning is given by the following formula

$$\omega_D = \left| \frac{\omega_r I_0 R}{V_c Q} \cos \phi_B \right| \approx \frac{\omega_r I_0 R}{V_c Q}$$

For a given beam current I_0 we will aim for low R/Q and ω_r and high gap voltage. Consider a superconducting cavity with the following parameters:

$$\frac{R}{Q} = 31.6 \Omega, \omega_r = 2\pi 476 \text{ MHz}, V_c = 2.5 \text{ MV}$$

Then at 11 A beam current the detuning is **94 kHz** - below the revolution frequency of 136 kHz. However at 23 A even this low-frequency cavity has to be detuned by **138 kHz**. At 952 MHz the detuning is doubled.

At first it would seem that for the $2 \cdot 10^{35} \text{ cm}^{-2} \text{ s}^{-1}$ machine the RF system can run with small detuning.

However in addition to generating the necessary gap voltage the RF system must restore the energy that the beam loses via synchrotron radiation, HOM and resistive wall losses.

Beam power requirements

Unfortunately at 2.5 MV cavity voltage the RF system can only provide 6-7 MW to the beam. Since at 11 A losses are 22.5 MW the outlined parameter set is unacceptable. Two ways to correct the situation while keeping the detuning low:

- Couple three times the power into each cavity (1.5 MW)
- Lower the cavity voltage - need to also drop R/Q. Need $V_c = 0.7\text{MV}$, $R/Q = 8.85$ - energy storage cavity?

Conclusion: For either 11 A or 23 A case cavity resonance will cross at least one synchrotron sideband unless cavities with very low R/Q are used. Strong RF feedback will be necessary to control the excitation of coupled-bunch instabilities.

RF parameters for the 476 MHz design

Will consider two cavity options

- Normal conducting cavities with RF feedback
- Superconducting cavities with RF feedback
- Energy storage cavity without RF feedback (parameters modeled after KEK-B ARES cavities)

Cavity parameters (by A. Novokhatski)

Cavity type	$R/Q, \Omega$	Unloaded Q	Cavity voltage, kV
PEP-II-Large (NC)	74.9	$3 \cdot 10^4$	637
KEKB-SC with tapers	44.9	10^9	778
ES (NC)	7.4	$1.1 \cdot 10^5$	521



Operating parameters at 476 MHz

Parameter	PEP-II-Large (NC)	KEKB-SC	ES (NC)
Wall power dissipation P_c , kW	90	0.007	165
Beam power P_b , kW	410	500	335
Detuning at 11 A beam current, kHz	615	302	74.4
Coupling factor β	5.5	74224	3
Loaded quality factor Q_l	$4.6 \cdot 10^3$	$1.4 \cdot 10^4$	$2.8 \cdot 10^4$
Loaded shunt impedance R_l , k Ω	340	605	204
Direct feedback gain	4.2	13	0
Peak driving impedance R_{\max} , k Ω	71	48	3.7
Number of cavities N_c	55	45	67
Total driving impedance $R_{\max} N_c$, M Ω	3.93	2.17	0.25
RF voltage, MV	35		
Beam power, MW	22.5		

Clearly the longitudinal driving impedance is much smaller with the energy storage cavities.

Only direct loop - expect approximately 5-10 times impedance reduction from the comb loop.



RF parameters for the 952 MHz design

Will consider two configurations

- Normal conducting cavities with RF feedback
- Superconducting cavities with RF feedback

Cavity parameters (by A. Novokhatski)

Cavity type	$R/Q, \Omega$	Unloaded Q	Cavity voltage, kV
New PEP-II (NC)	66.4	$3 \cdot 10^4$	628
PEP-SC	31.6	10^9	783

Operating parameters at 952 MHz

Parameter	PEP-II-Large (NC)	PEP-SC
Wall power dissipation P_c , kW	99	0.01
Beam power P_b , kW	401	500
Detuning at 11 A beam current, kHz	2316	839
Coupling factor β	5.1	48956
Loaded quality factor Q_l	$5 \cdot 10^3$	$2 \cdot 10^4$
Loaded shunt impedance R_l , k Ω	329	613
Direct feedback gain	2.3	10
Peak driving impedance R_{\max} , k Ω	110	63
Number of cavities N_c	49	40
Total driving impedance $R_{\max} N_c$, M Ω	5.4	2.5
RF voltage, MV	30.8	31.3
Beam power, MW	19.7	20

Not a big change in the residual impedance relative to 11 A/476 MHz case.

Options for improving impedance control

The numbers above only included wideband direct feedback loop. Adding the comb feedback we can lower the impedance by a factor of 5-10.

Doing all of the above (direct and comb loops) would only reproduce the feedback topology used in PEP-II with appropriate technical improvements. What else can we do to control the impedance?

Some ideas:

- Reduce feedback loop group delay by placing klystrons and LLRF very close to the cavities (factor of 2 in delay/gain?)
- Impedance shaping feedback loop - only suppress the impedance that drives coupled-bunch instabilities (single-sideband comb filter).
- Cavities with lower R/Q to get the detuning under one revolution harmonic.
- Energy storage cavities?

Ways to alleviate the effect of the driving impedance:

- Momentum compaction as low as possible
- Push the gap voltage as high as possible without adding extra cavities. Impedance scales with N_c , growth rates with $1/(\sqrt{V_{rf}}) \sim 1/(\sqrt{N_c})$

Single sideband comb filter

Currently the comb filter has a symmetric response around each revolution harmonic. The positive sideband peak reduces the real part of the impedance exciting eigenmode m . The negative sideband peak increases the real part of the impedance exciting eigenmode $-m$.

Idea: reshape comb filter spectrum to suppress the lower sideband.

Issues: feedback stability margins, synchrotron tune shifts from larger residual reactive impedance.

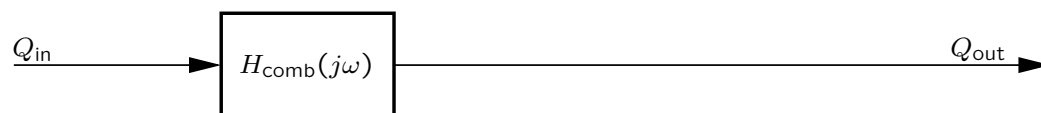
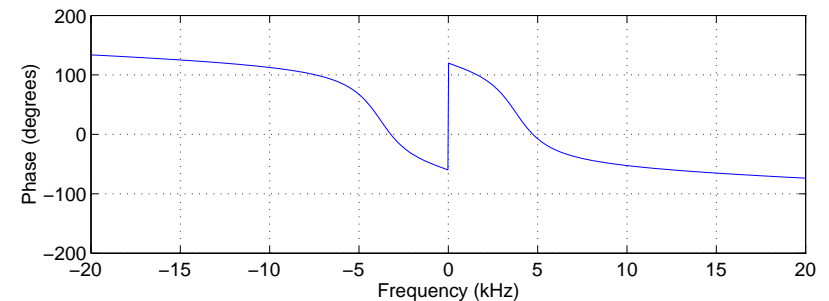
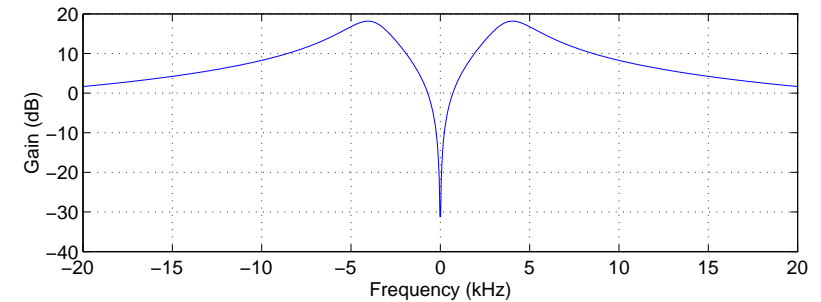

As a side effect new processing topology would allow to implement cross-terms in the equalizer filter.

Single sideband comb filter

Currently the comb filter has a symmetric response around each revolution harmonic. The positive sideband peak reduces the real part of the impedance exciting eigenmode m . The negative sideband peak increases the real part of the impedance exciting eigenmode $-m$.

Idea: reshape comb filter spectrum to suppress the lower sideband.

Issues: feedback stability margins, synchrotron tune shifts from larger residual reactive impedance.

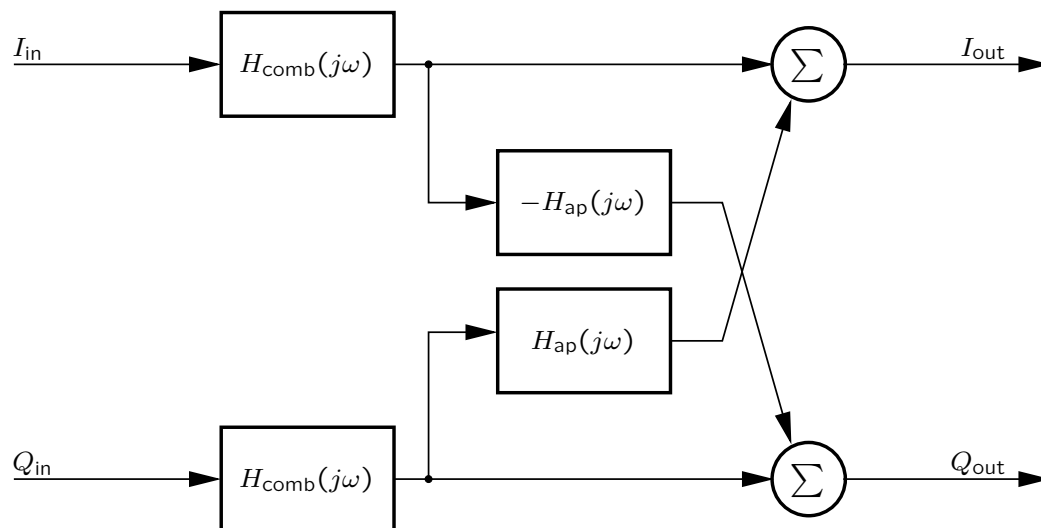
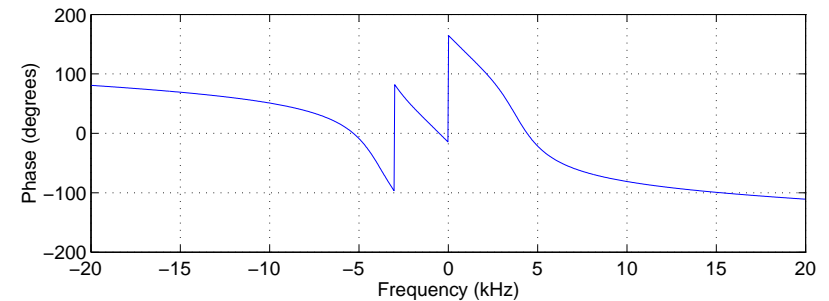
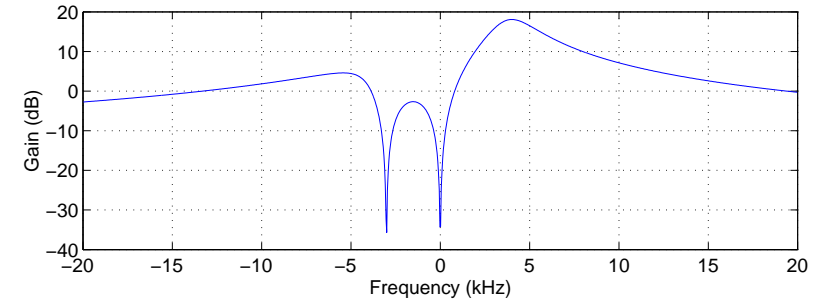

As a side effect new processing topology would allow to implement cross-terms in the equalizer filter.



Summary

Proposed Super-PEP-II designs will operate above dipole coupled-bunch instability thresholds in all three planes. A coupled-bunch feedback channel capable of sampling at 1+ GHz is **a must** to support longitudinal and transverse feedback at ~1 ns bunch spacings!

In the longitudinal direction strong coupled-bunch instabilities will be excited by the fundamental impedance of the RF cavities.

Using existing RF feedback topologies around the klystron-cavity system will reduce the driving impedances to 250-500 k Ω - similar to the current PEP-II impedances, but at 10-20 times the beam current.

We need to explore options for cavity detuning under one revolution harmonic in the 476 MHz, 11 A storage ring. This would bring a dramatic reduction in the residual impedances as demonstrated by the energy storage cavity example.

For the Super-PEP-II with 952 MHz RF frequency and 23 A currents better feedback mechanisms than exist now will be needed to control the impedance. Some headroom might be gained from optimizing the accelerator parameters for lower growth rates.



January 20, 2004

Acknowledgments

Many thanks to R. Akre, M. Browne, J. Byrd, P. Corredoura, A. Drago, J. Fox, A. Gallo, H. Hindi, S. Prabhakar, F. Pedersen, H. Schwarz, M. Serio, R. Tighe for numerous valuable discussions and ideas.

Work supported by U.S. Department of Energy contract DE-AC03-76SF00515